

B346857196BRU



Look inside for Assembly Manual

Check us out!



littleseedskids.com

6857196BRU Piper Bookcase



Keep this Assembly Manual for future reference

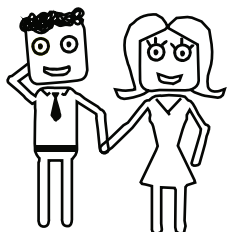
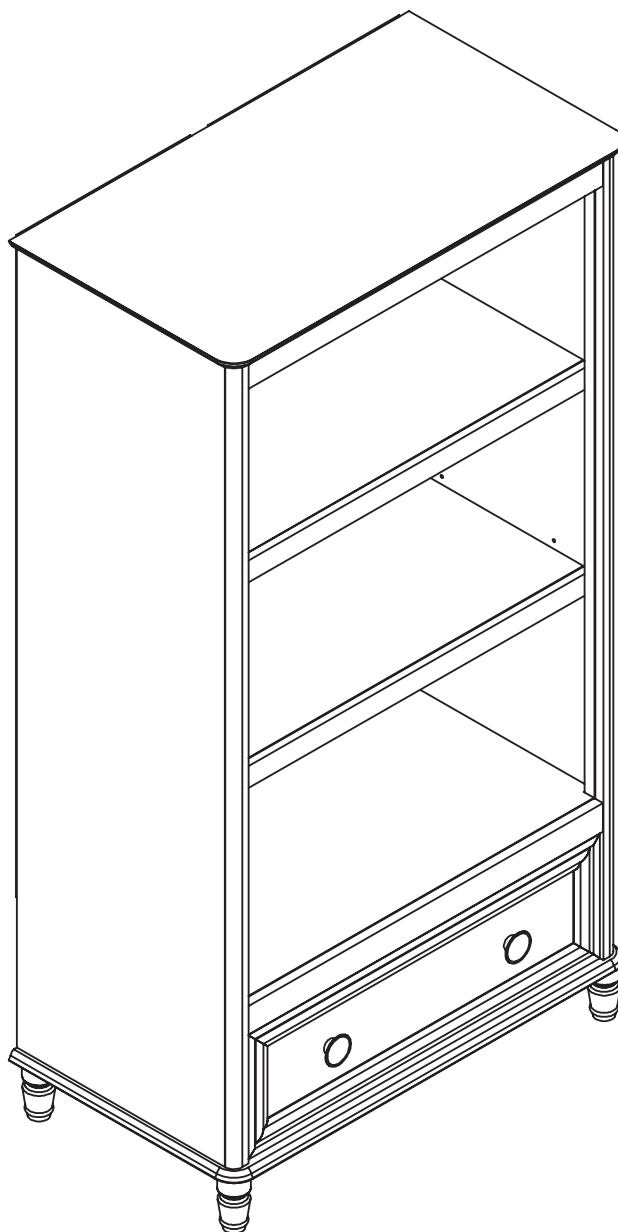

Two Adults
recommended
for assembly

This product is not intended for commercial use

Do NOT return this product!

For missing or broken parts
- Visit littleseedskids.com
- Call 1-800-489-3351

Follow little seeds on





Do NOT return this product!
Contact our friendly customer service team first for help

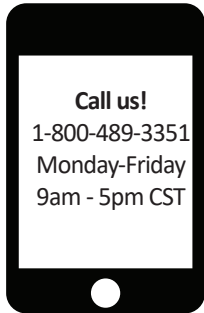

Visit littleseedskids.com to view the limited warranty valid in the U.S and Canada

Assembly Tips



Helpful Hints

PEOPLE NEEDED FOR ASSEMBLY: **1-2**
ESTIMATED ASSEMBLY TIME: **1 HOUR**

- Open your item in the area you plan to keep it for less heavy lifting
- Identify, sort and count the parts before attempting assembly
- Compression dowels are tapped in with a hammer
- Slides are labeled with a R (right) and L (left) for proper placement
- Make sure to always face the point on the top of the Cam Lock towards the outer edge
- Use all the nails provided for the back panel and spread them out equally
- Back Panel must be used to make sure your unit is sturdy
- Do NOT use harsh chemicals or abrasive cleaners on this item
- Never push, pull, or drag your furniture



Before You Start

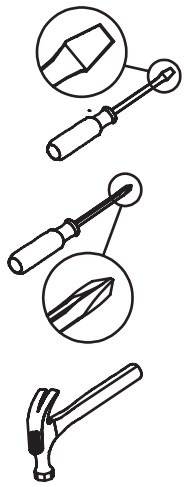

- ✓ Read through each step carefully and follow the proper order
- ✓ Separate and count all your parts and hardware
- ✓ Give yourself enough room for the assembly process
- ✓ Have the following tools: Flat Head Screwdriver, #2 Phillips Head Screwdriver and Hammer
- ✓ Caution: If using a power drill or power screwdriver for screwing, please beware to slow down and stop when screw is tight. Failure to do so may result in stripping the screw,

Cam Lock Fastening System

This Cam Lock Fastening System will be used throughout the assembly process.

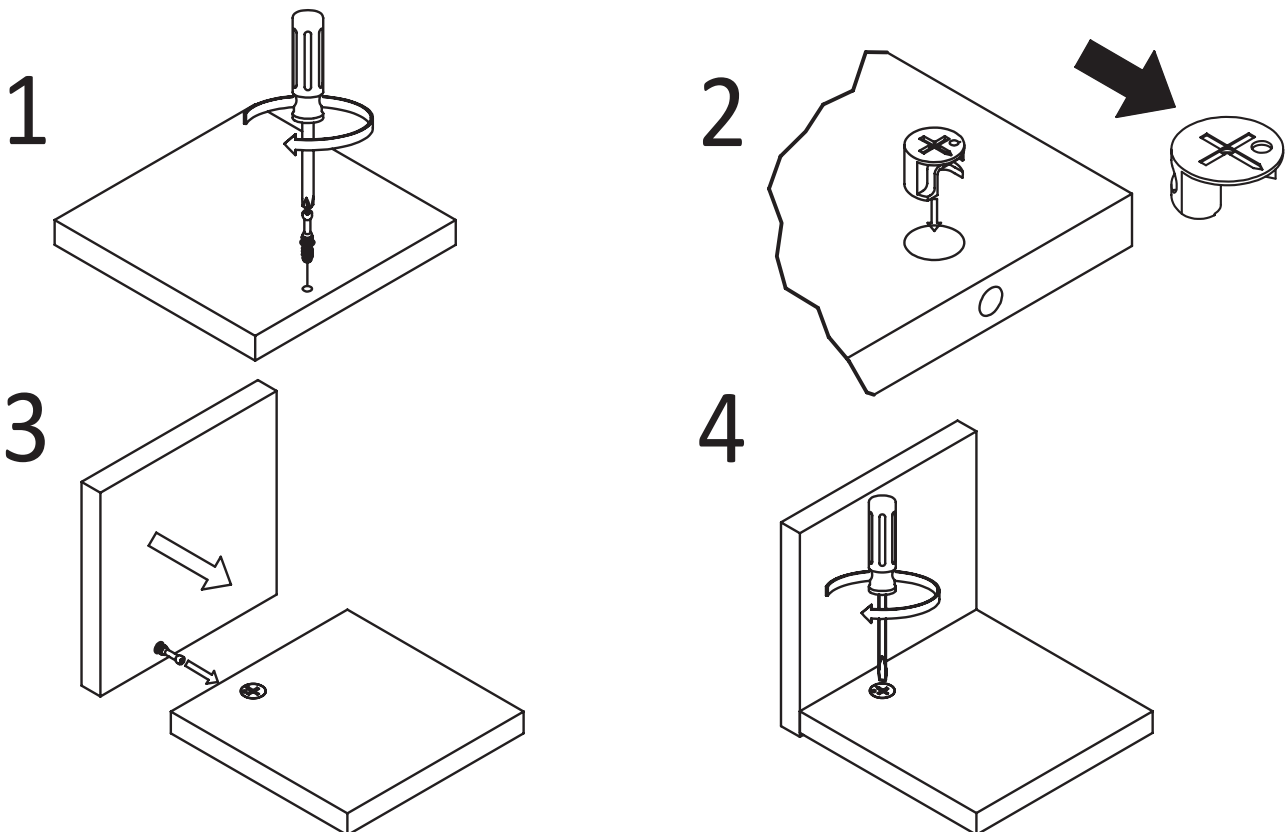

Board Identification

Not actual size

1

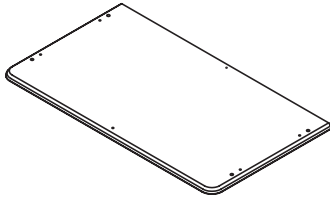

x1
T6857196010
TOP PANEL

2

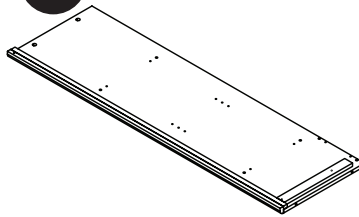

x1
T6857196020
LEFT SIDE PANEL

3

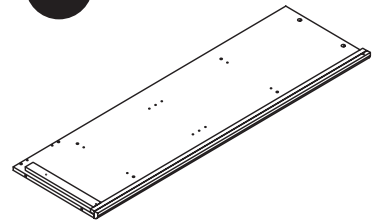

x1
T6857196030
RIGHT SIDE PANEL

4

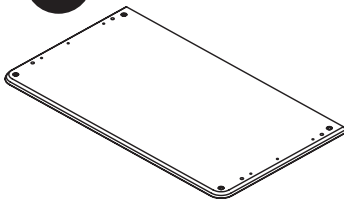

x1
T6857196040
BOTTOM PANEL

5



x4
T6857196050
LEG

6

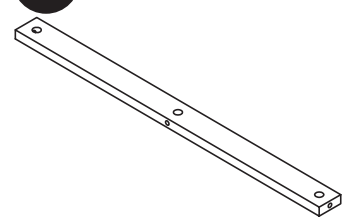

x1
T6857196060
TOP MOLDING

7

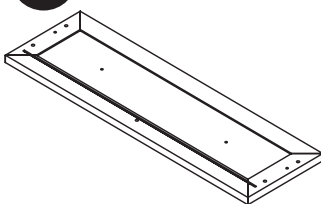

x1
T6857196070
FRONT DRAWER

8

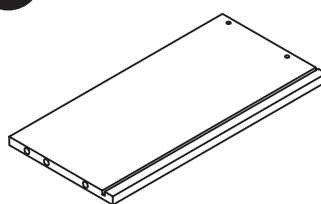

x1
T6857196080
LEFT SIDE DRAWER

9

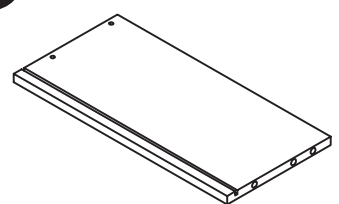

x1
T6857196090
RIGHT SIDE DRAWER

Board Identification

Not actual size

10

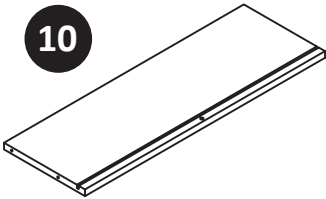

x1
T6857196100
BACK DRAWER

11

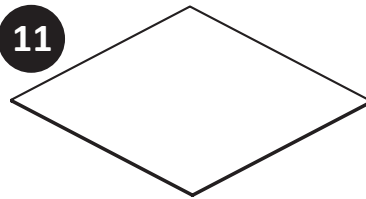

x1
T6857196110
BOTTOM DRAWER

12

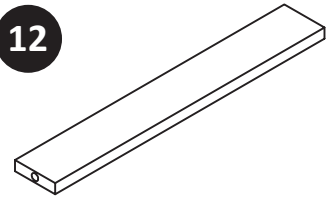

x1
T6857196120
DRAWER SUPPORT

13

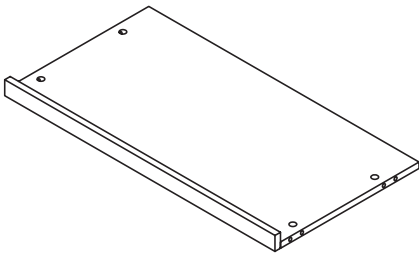

x1
T6857196130
UPPER SHELF

14

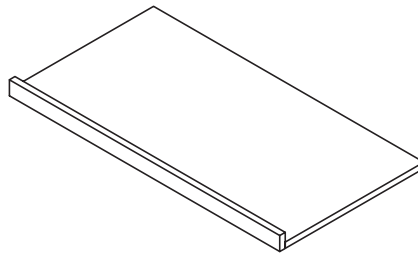

x1
T6857196140
MIDDLE SHELF

15

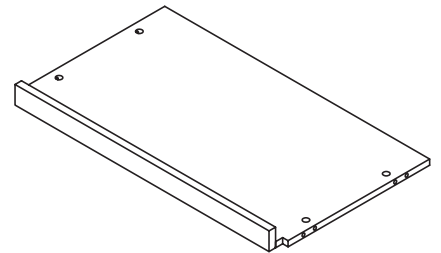

x1
T6857196150
LOWER SHELF

16

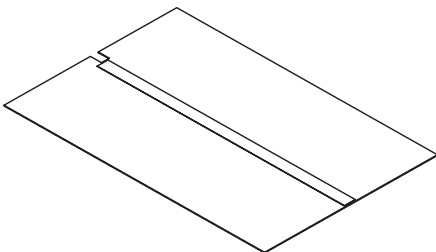

x1
T6857196160
UPPER BACK PANEL

17

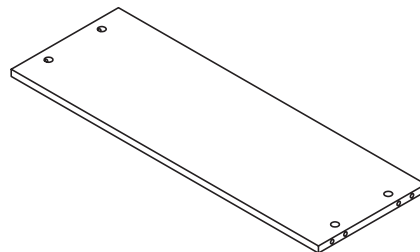

x1
T6857196170
LOWER BACK PANEL

Part List Actual size



x21
TUD0001
Cam Bolt

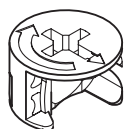

x21
TUD0002
Cam Lock
15-12

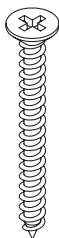

x10
TUD0009
CBS 4 x 38

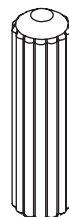

x20
TUD0004
DOWEL 8 X 25



x6
TUD0005
DOWEL 6 X 25

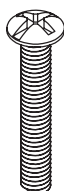

x2
TUD0011
PH M4 X 12

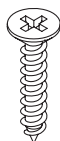

x12
TUD0008
CBS 3.5 x 16



x24
TUD0006
NAIL



x4
TUD0028
SHELF HOLDER

Hardware Bag Reference Number:
26857196BRU0



Part List

Not actual size

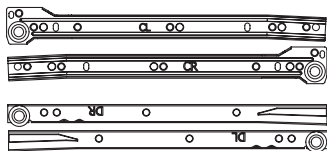

x1 SET
TUD0017
DRAWER SLIDE
350 MML



x2
TUD0013
ROUND KNOB

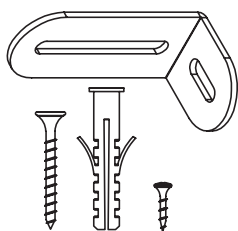

x1 set
TUD0021
ANTI TIPPING KIT



Step 1

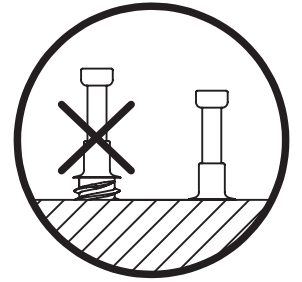
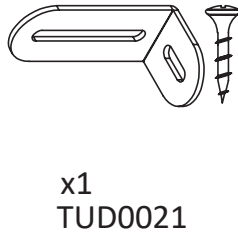
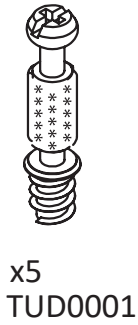
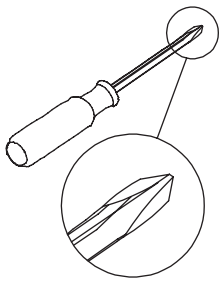

Attach the Cam Lock. For anti tipping bracket, do not fully tighten in this step.

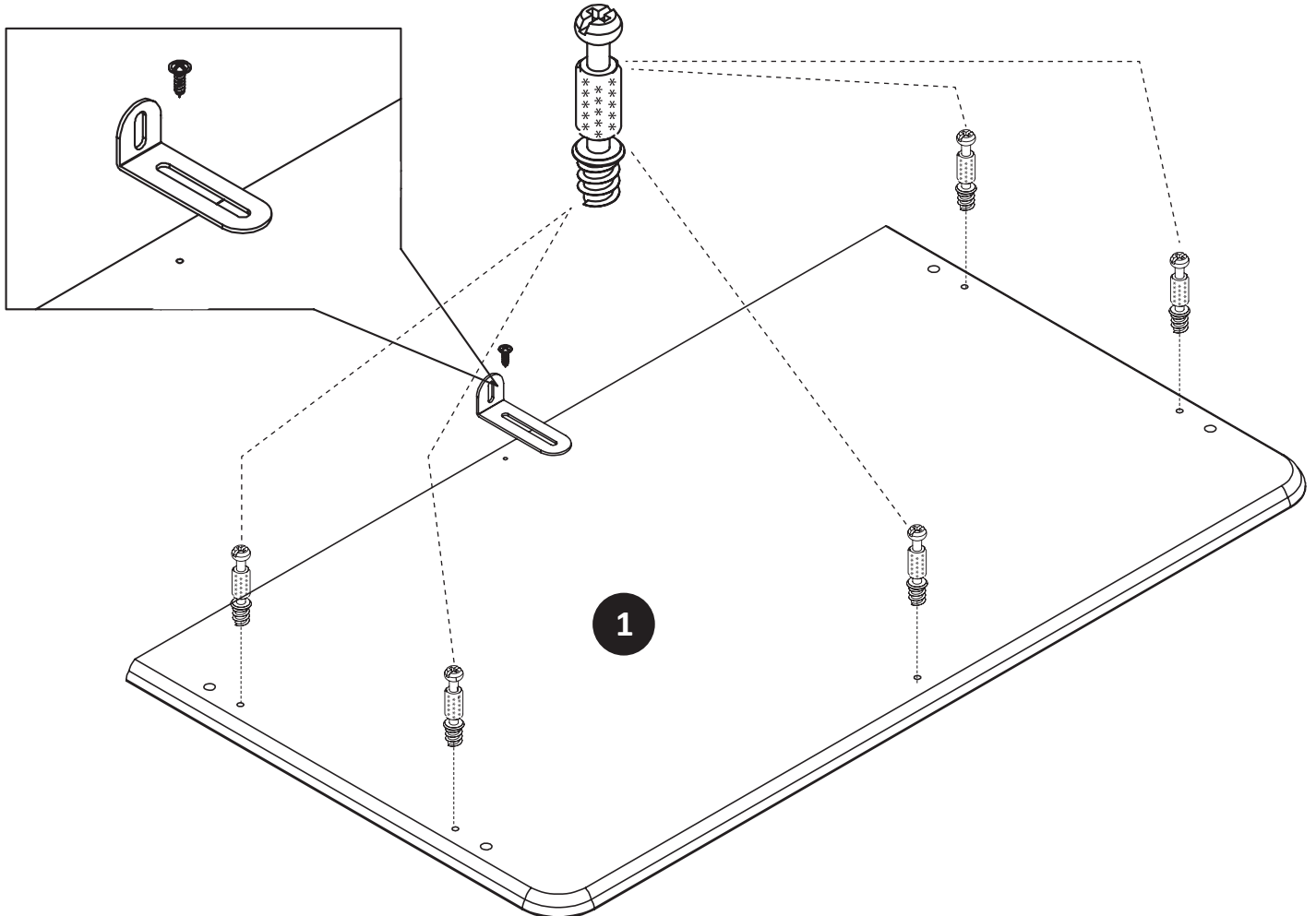

* raw edges are shaded

Step 2

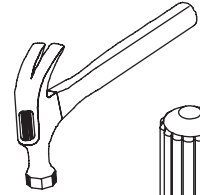
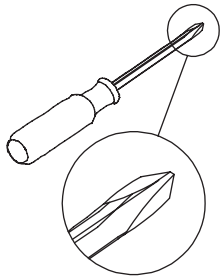

x7
TUD0001

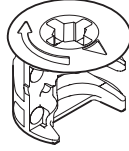

x2
TUD0002



x4
TUD0004

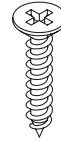

x3
TUD0008



x1 (CL)
TUD0017

Preparation of left side panel

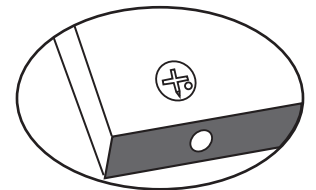

Proper orientation of CAM LOCK

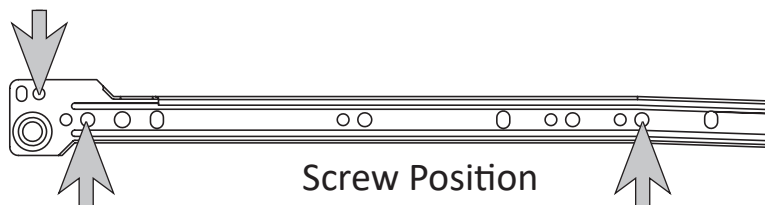
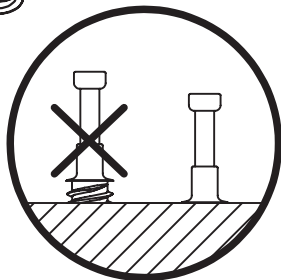
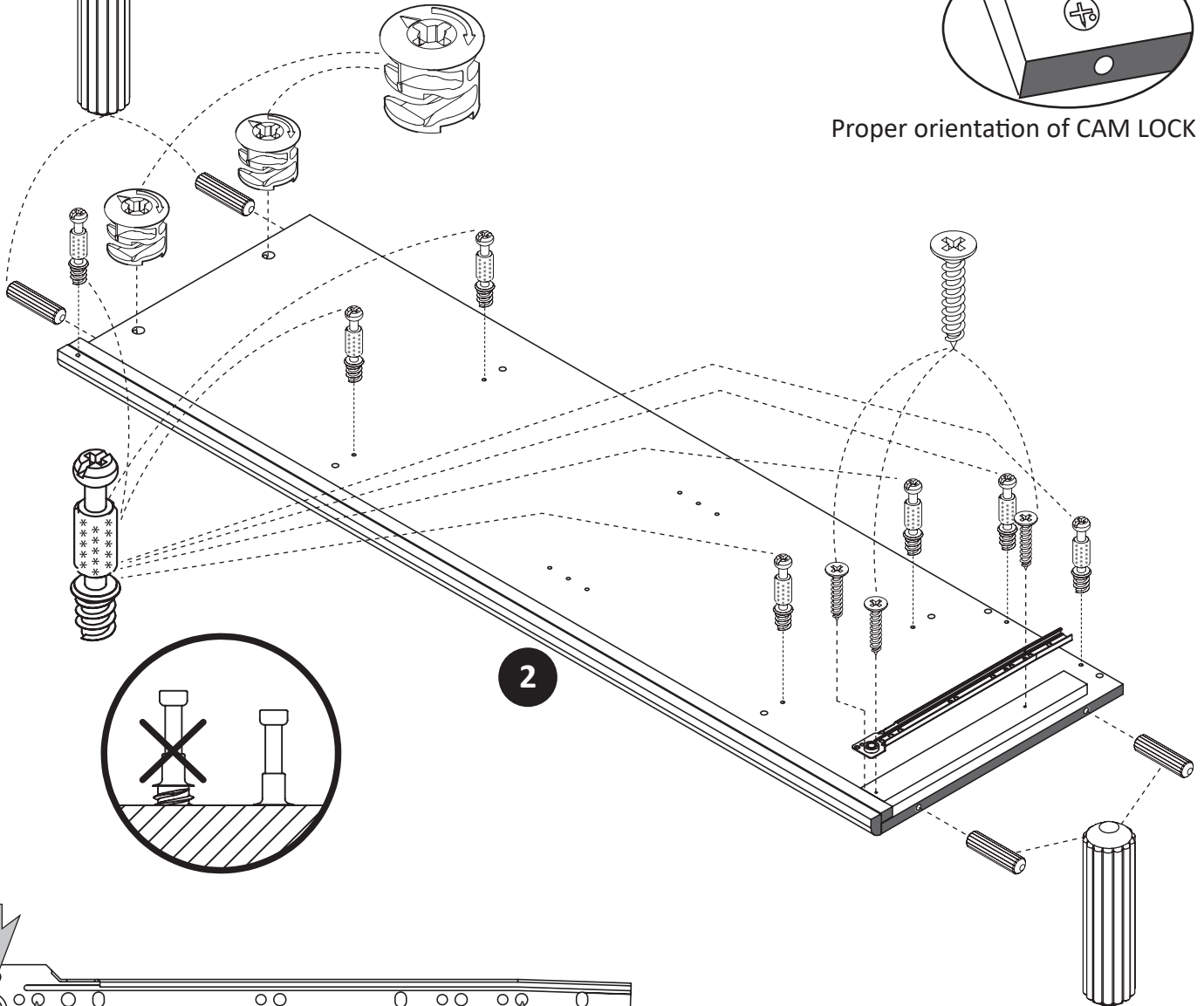

* raw edges are shaded

Step 3

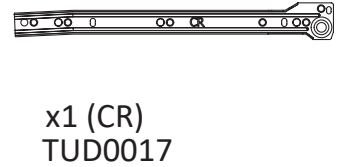
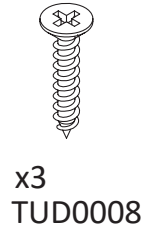
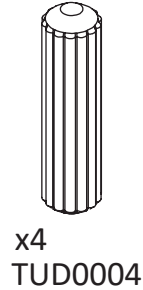
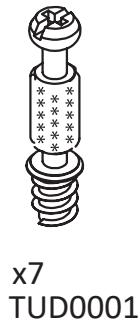
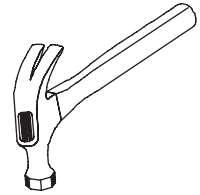
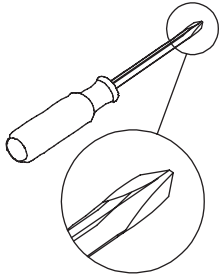

Preparation of right side panel

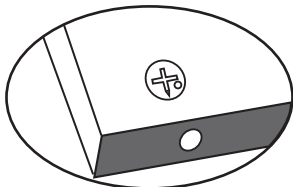

Proper orientation of CAM LOCK

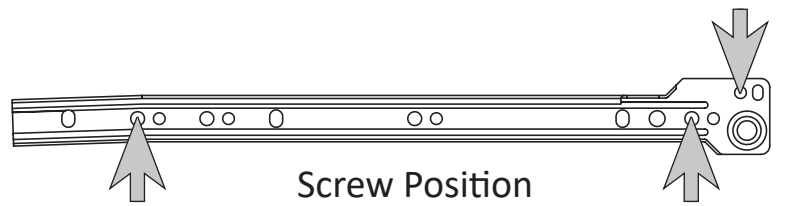
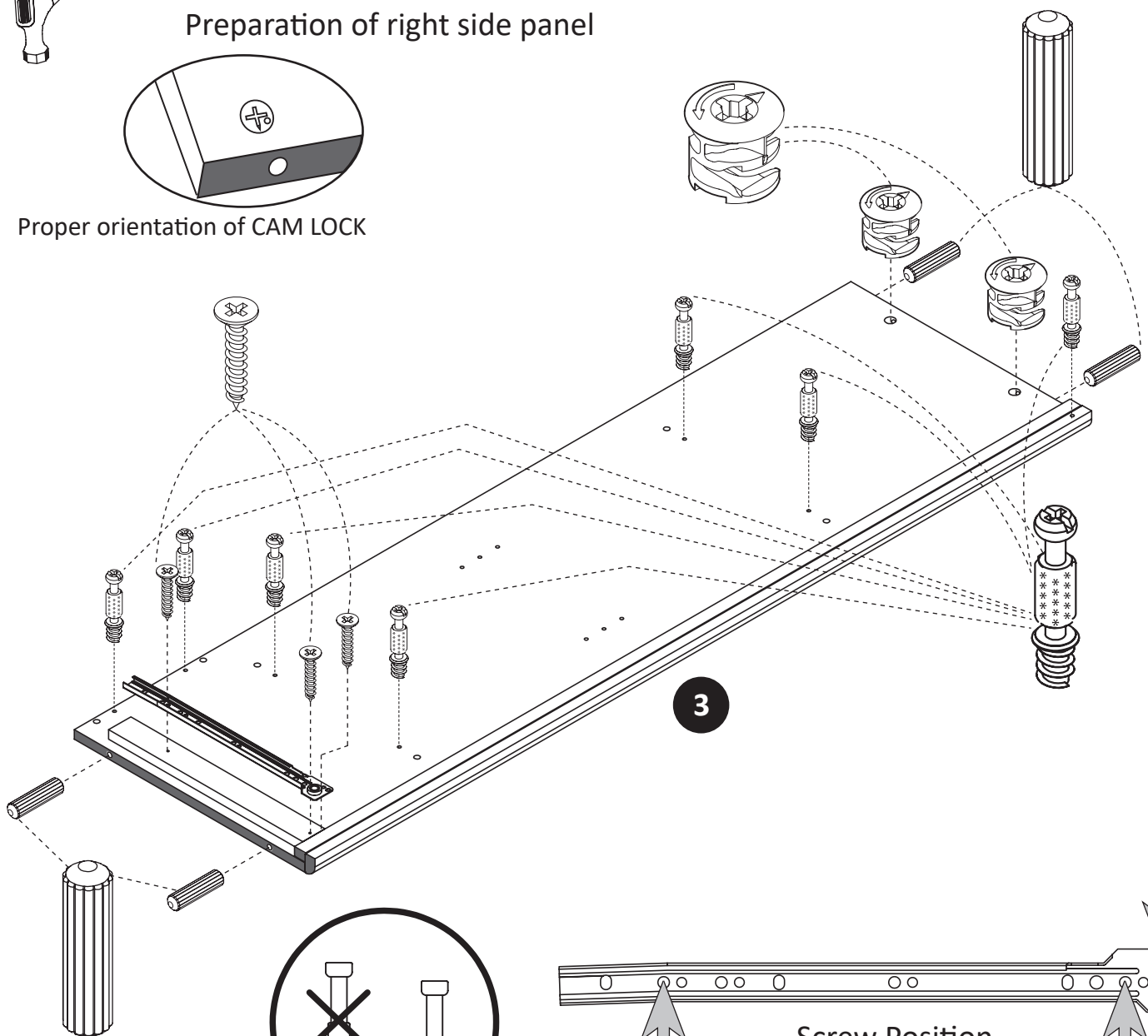

* raw edges are shaded

Step 4

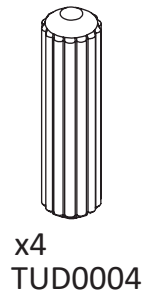
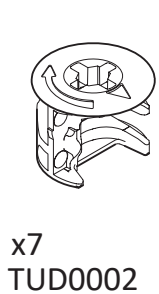
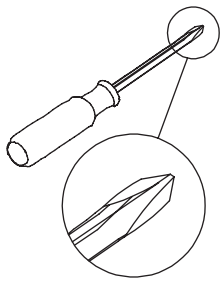

Preparation of lower back panel & top molding

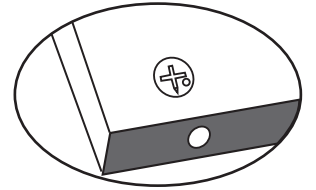

Proper orientation of CAM LOCK

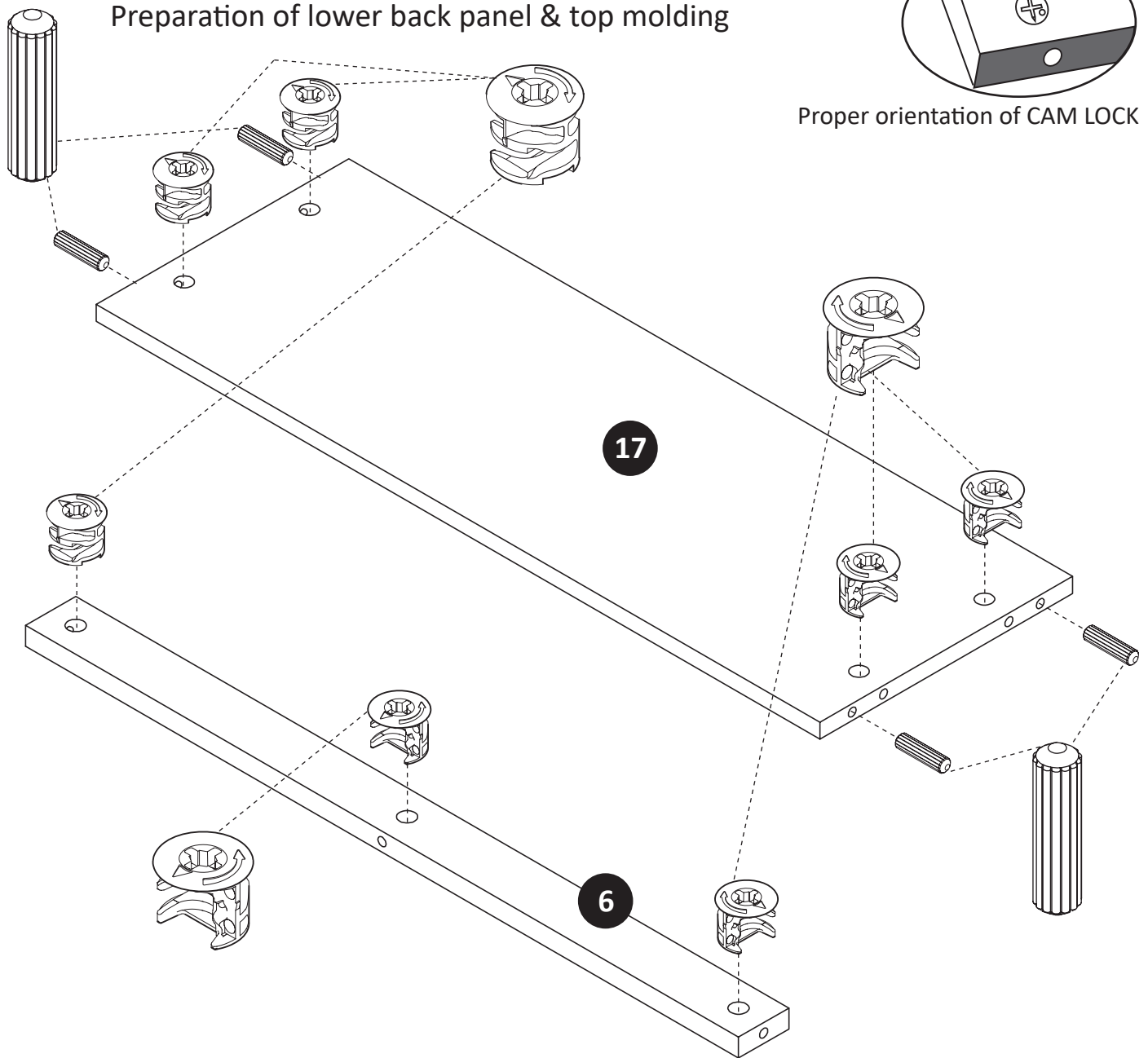

* raw edges are shaded

Step 5

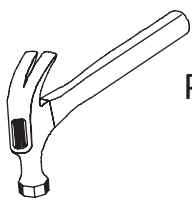
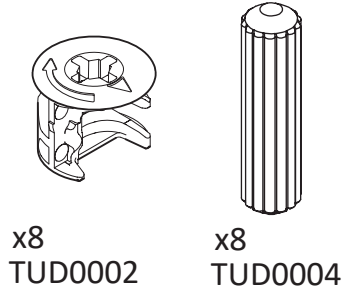
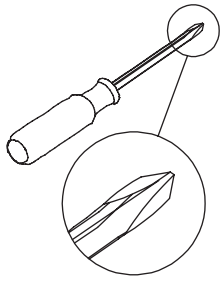

Preparation of upper & lower shelves

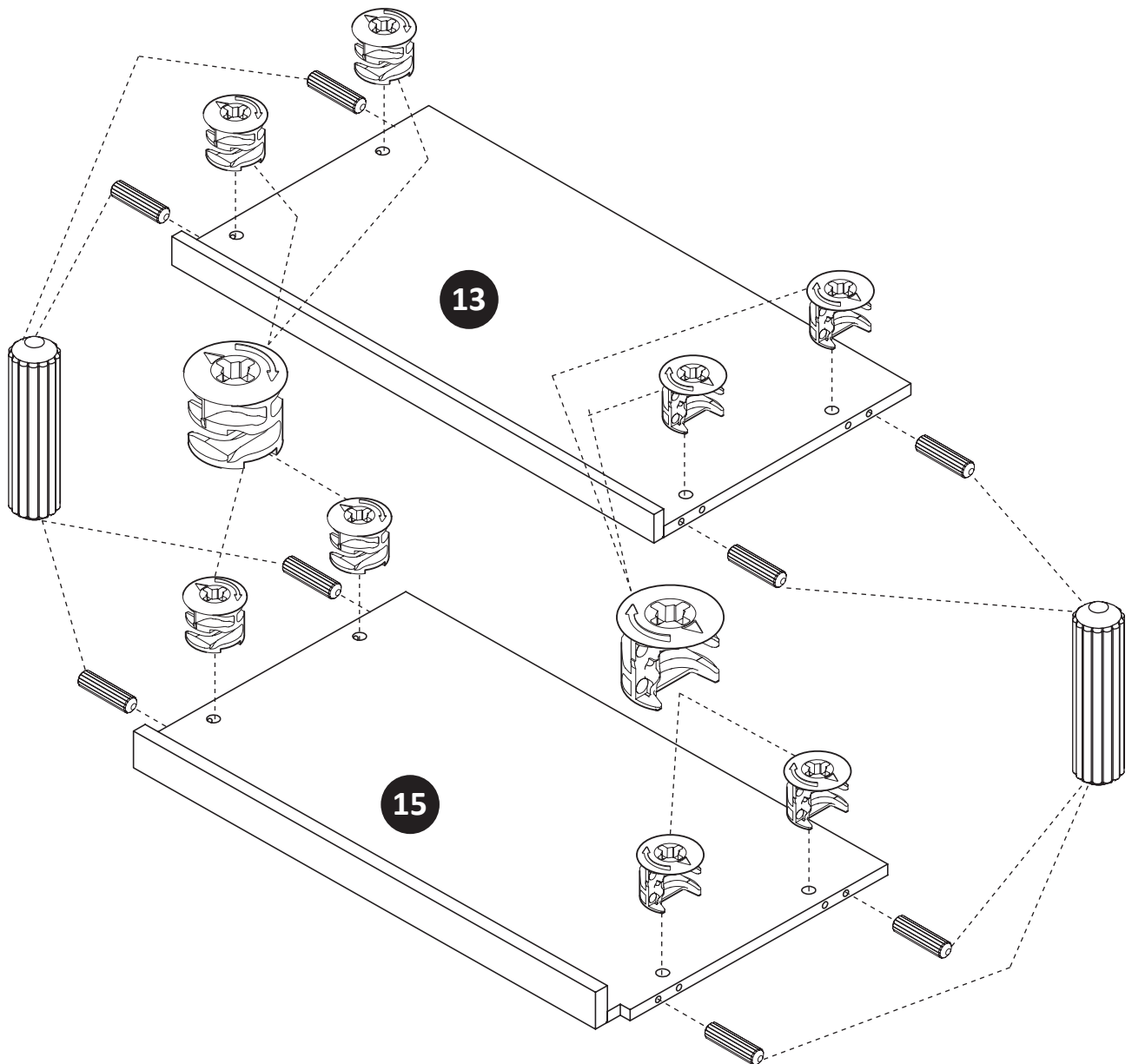

* raw edges are shaded

Step 6

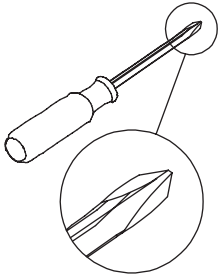

x2
TUD0001

Preparation of front drawer

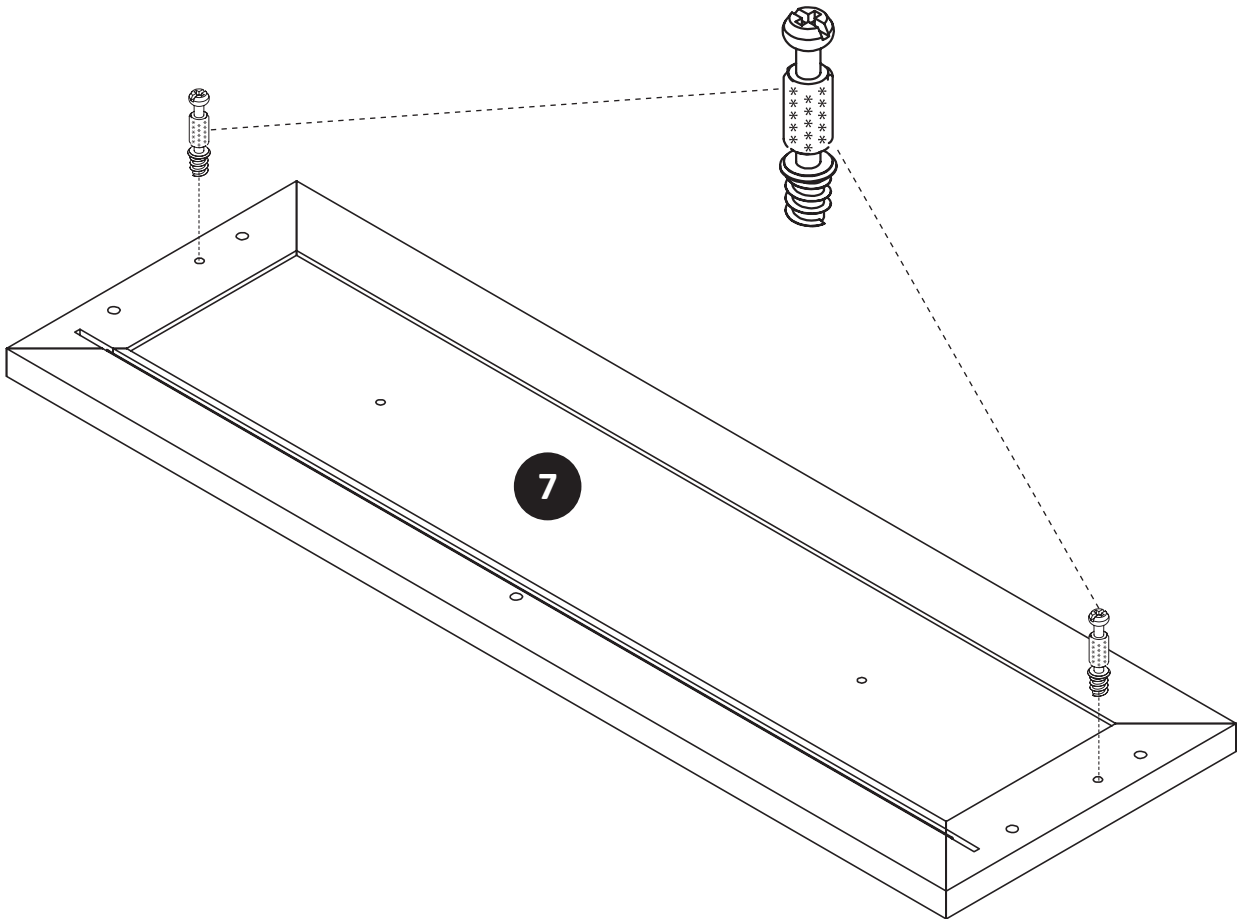

* raw edges are shaded

Step 7

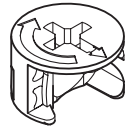
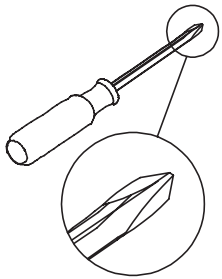

x2
TUD0002

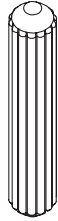

x4
TUD0005

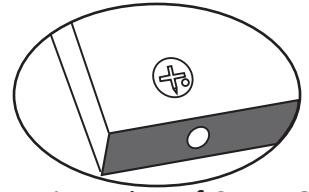

Proper orientation of CAM LOCK

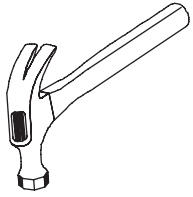

Preparation of left & right side drawer

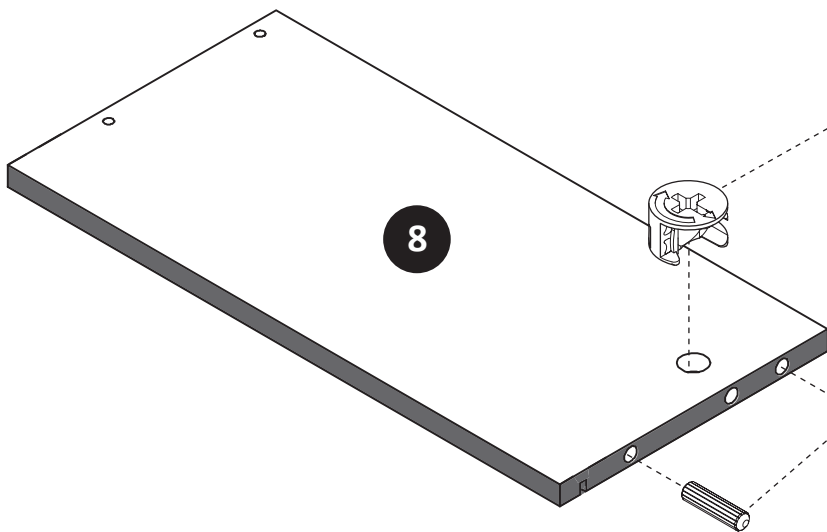
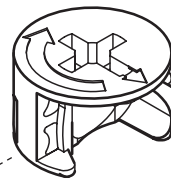
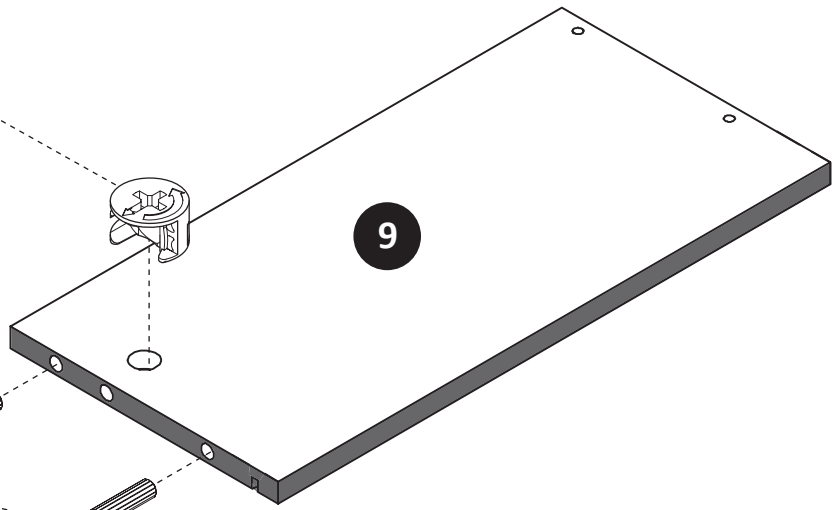
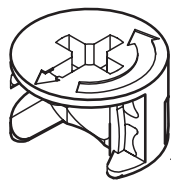

* raw edges are shaded

Step 8

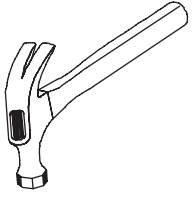

x2
TUD0005

Preparation of drawer support

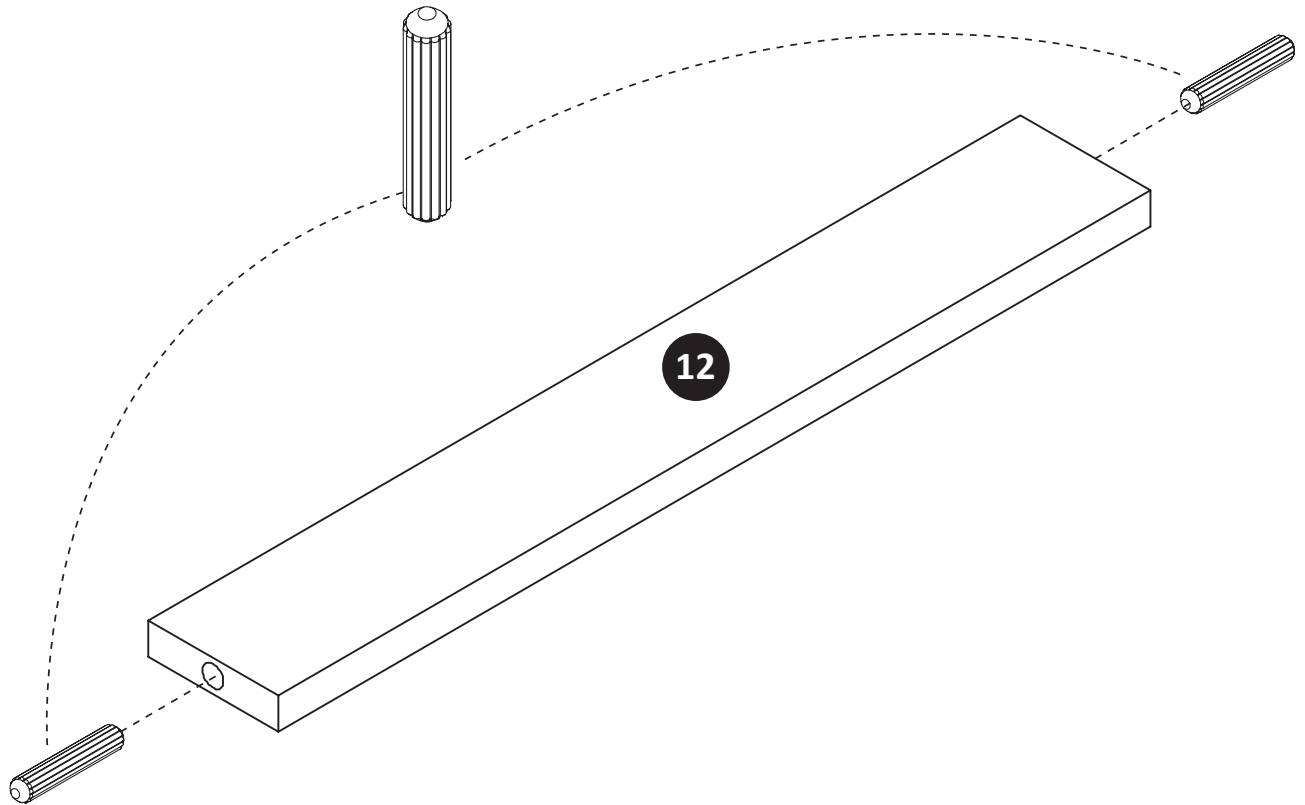

* raw edges are shaded

Step 9

Attach left side drawer to front drawer.

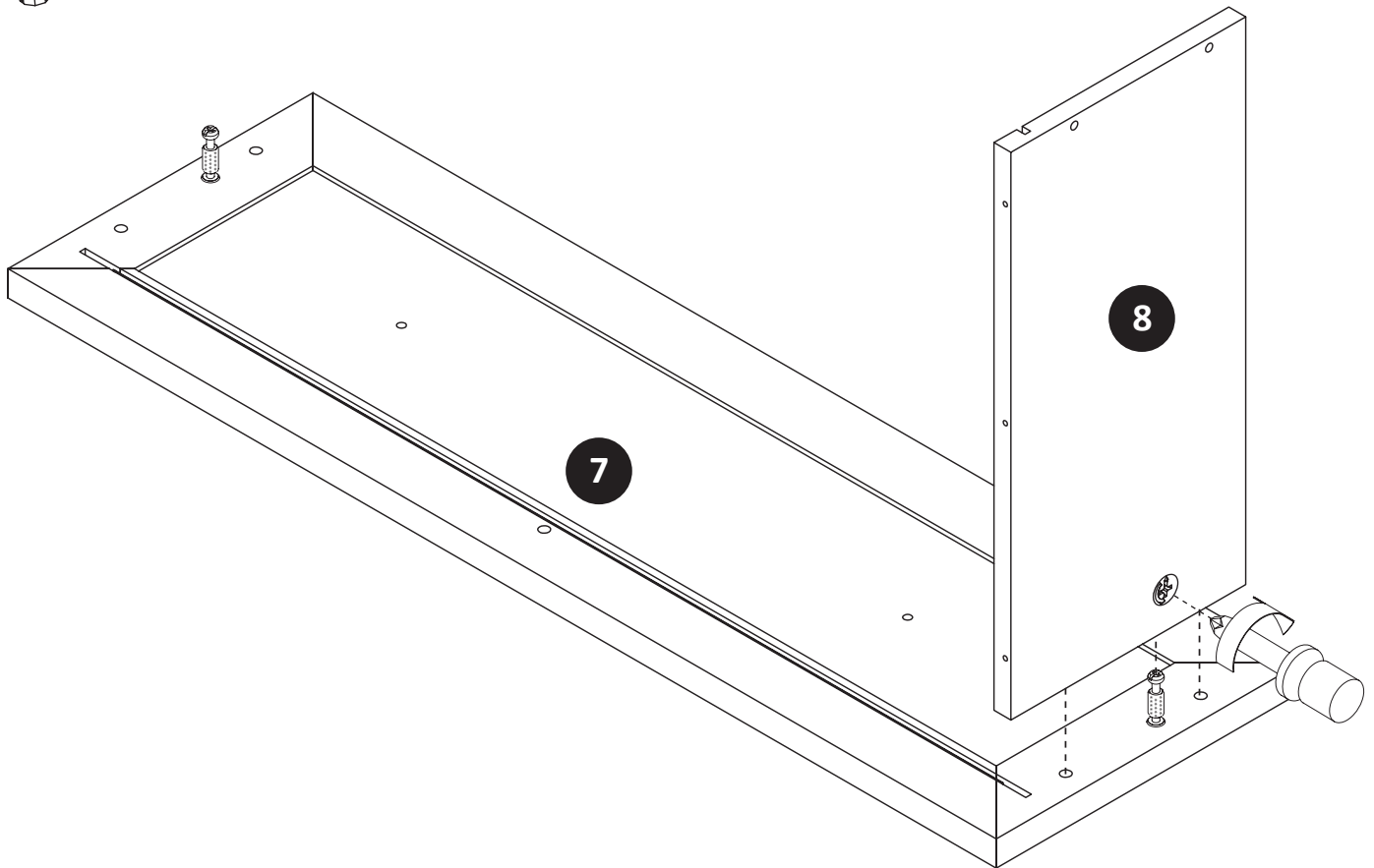
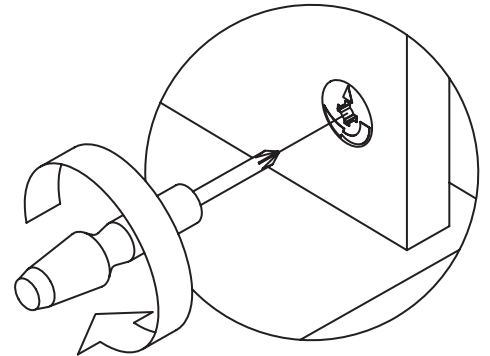
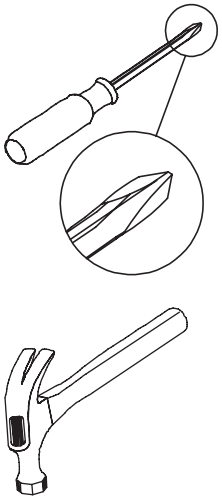

* raw edges are shaded

Step 10

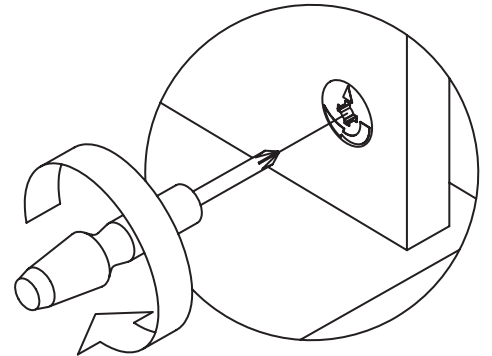
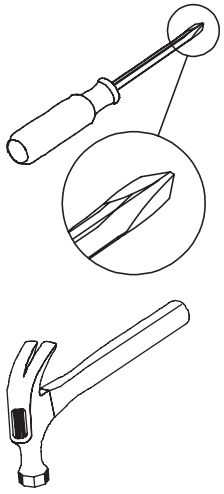

Attach right side drawer to front drawer

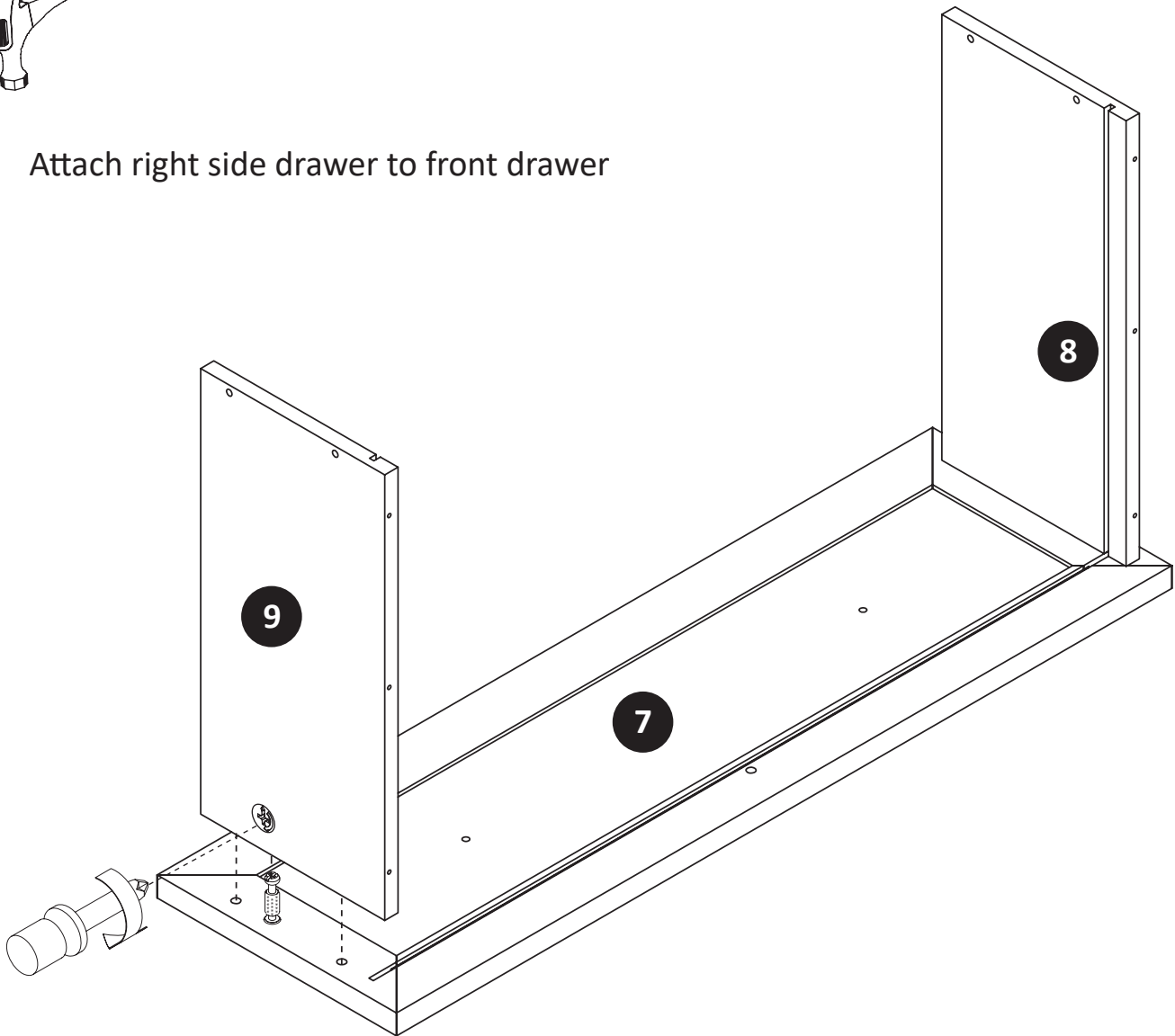

* raw edges are shaded

Step 11

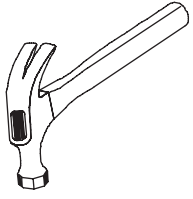

Attach drawer support to front drawer

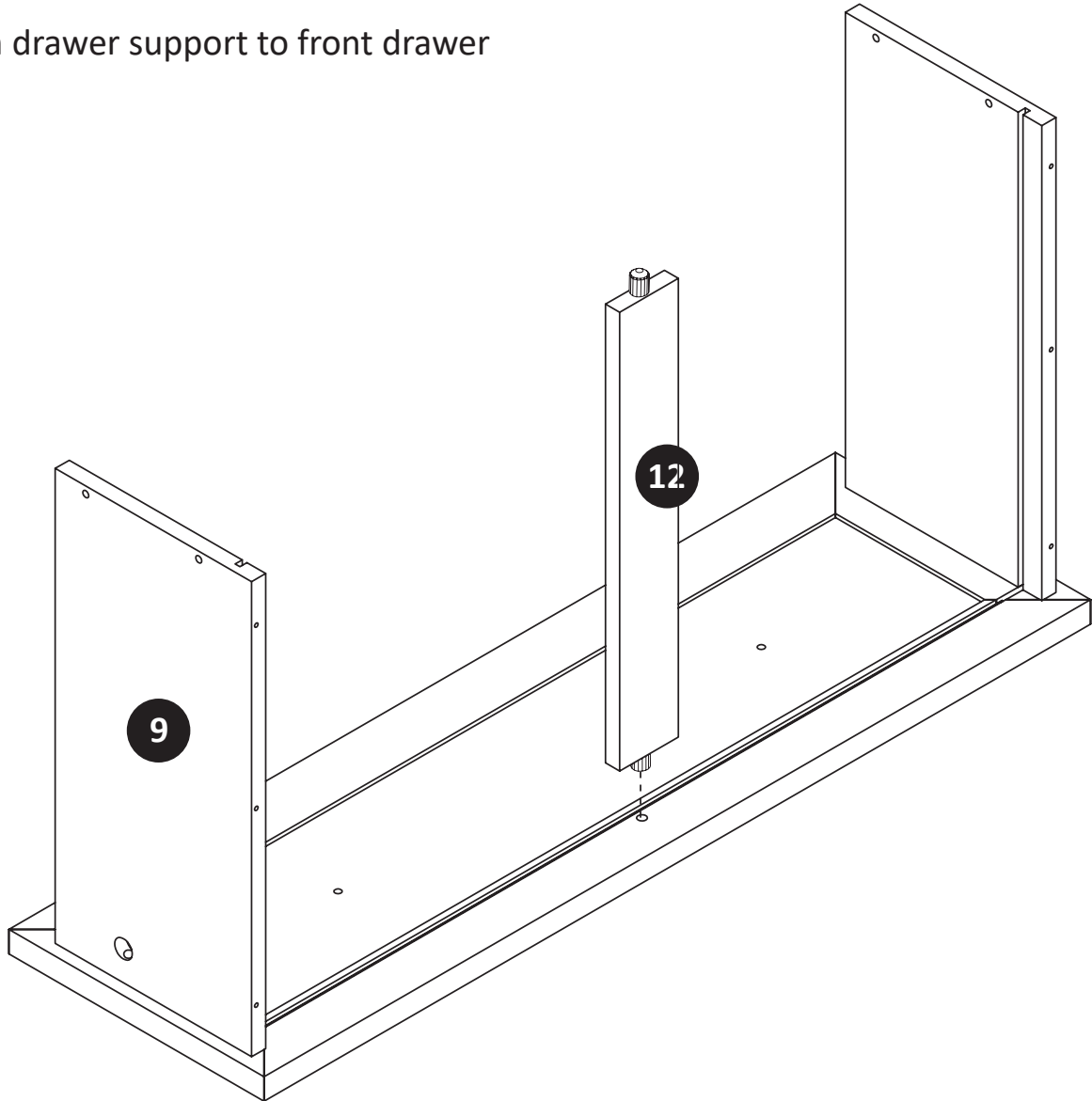

* raw edges are shaded

Step 12

Slotting in bottom drawer

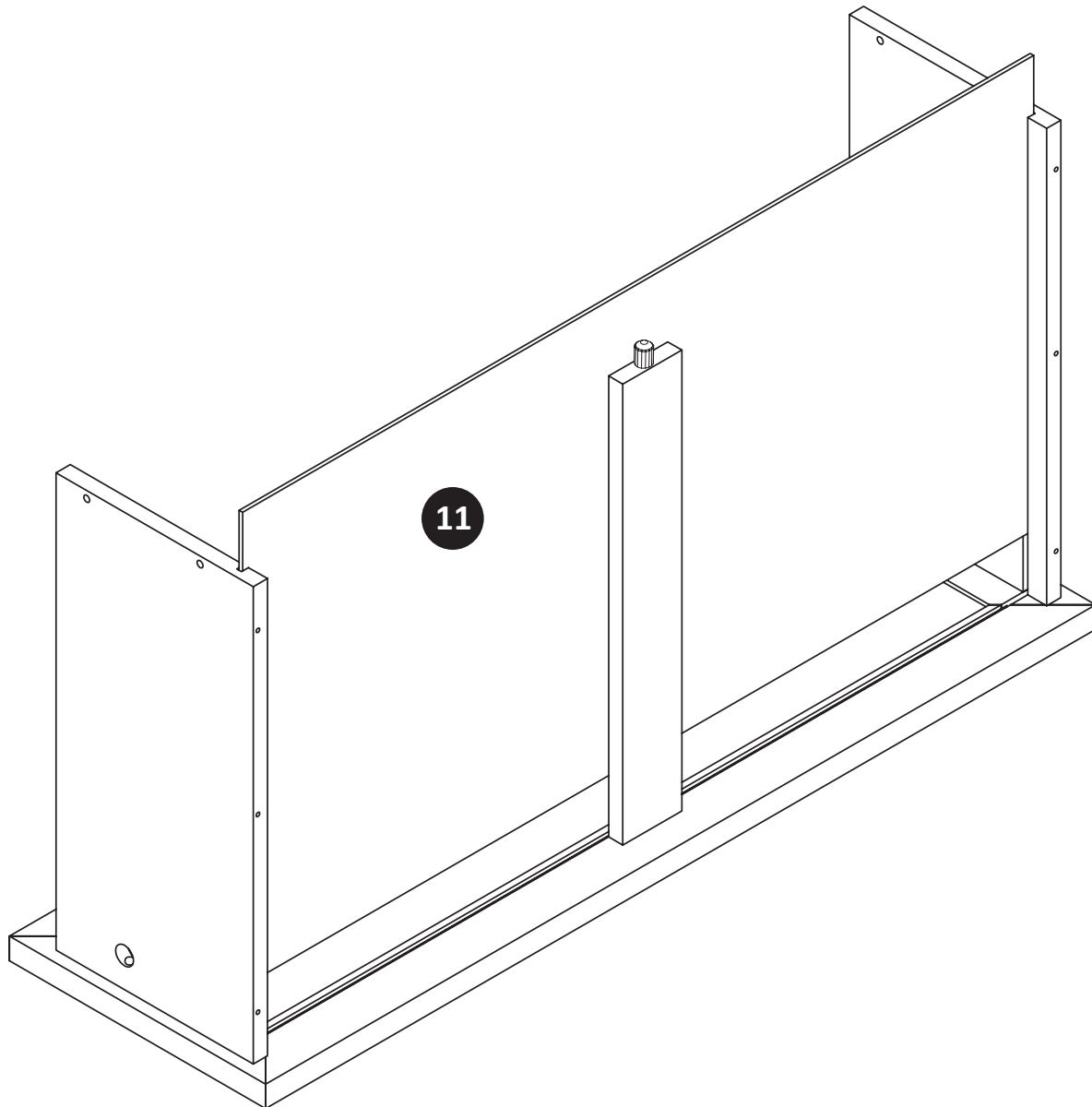

* raw edges are shaded

Step 13

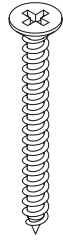
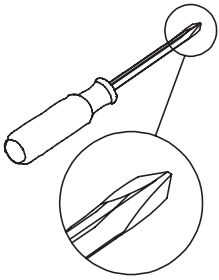

x4
TUD0009

Attach the back drawer with screw

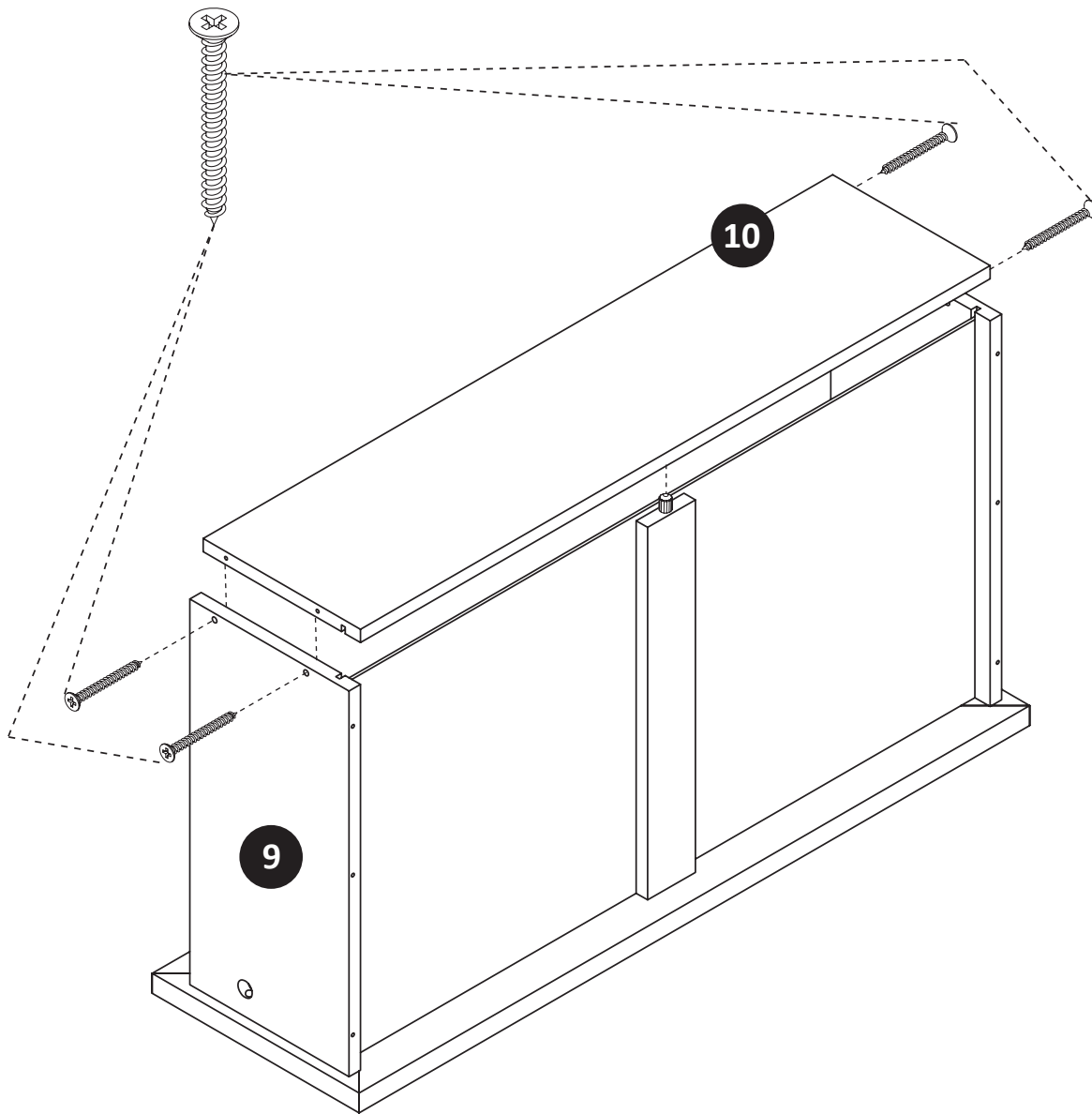

* raw edges are shaded

Step 14

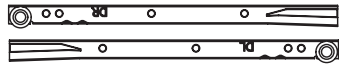
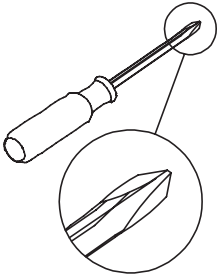

x1 (DR & DL)
TUD0017

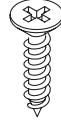

x6
TUD0008

Attach drawer slide for drawer box

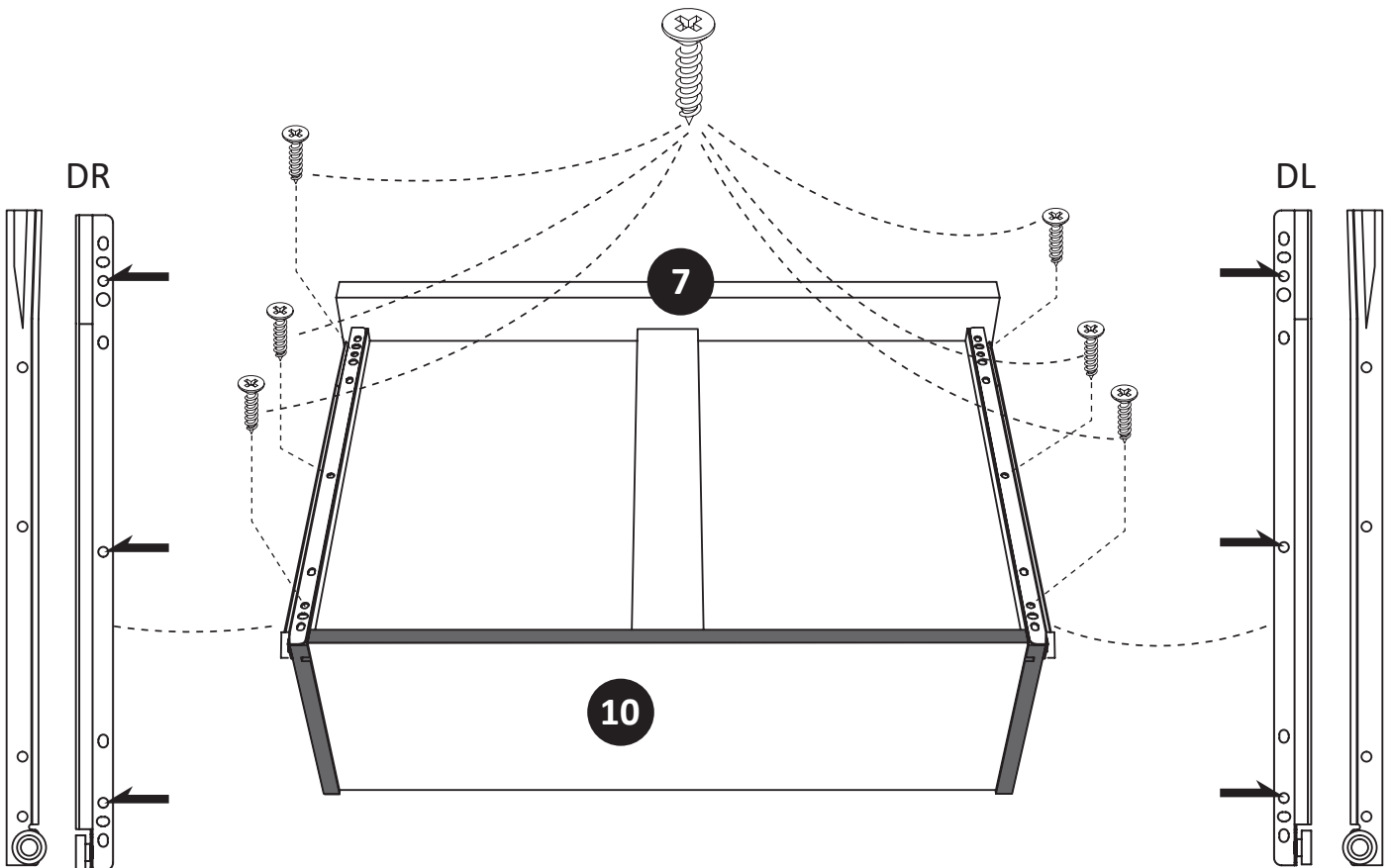

* raw edges are shaded

Step 15

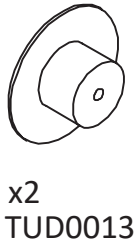
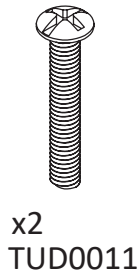
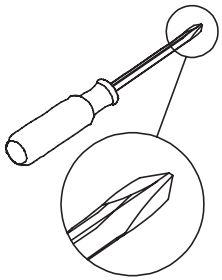

Knob installation

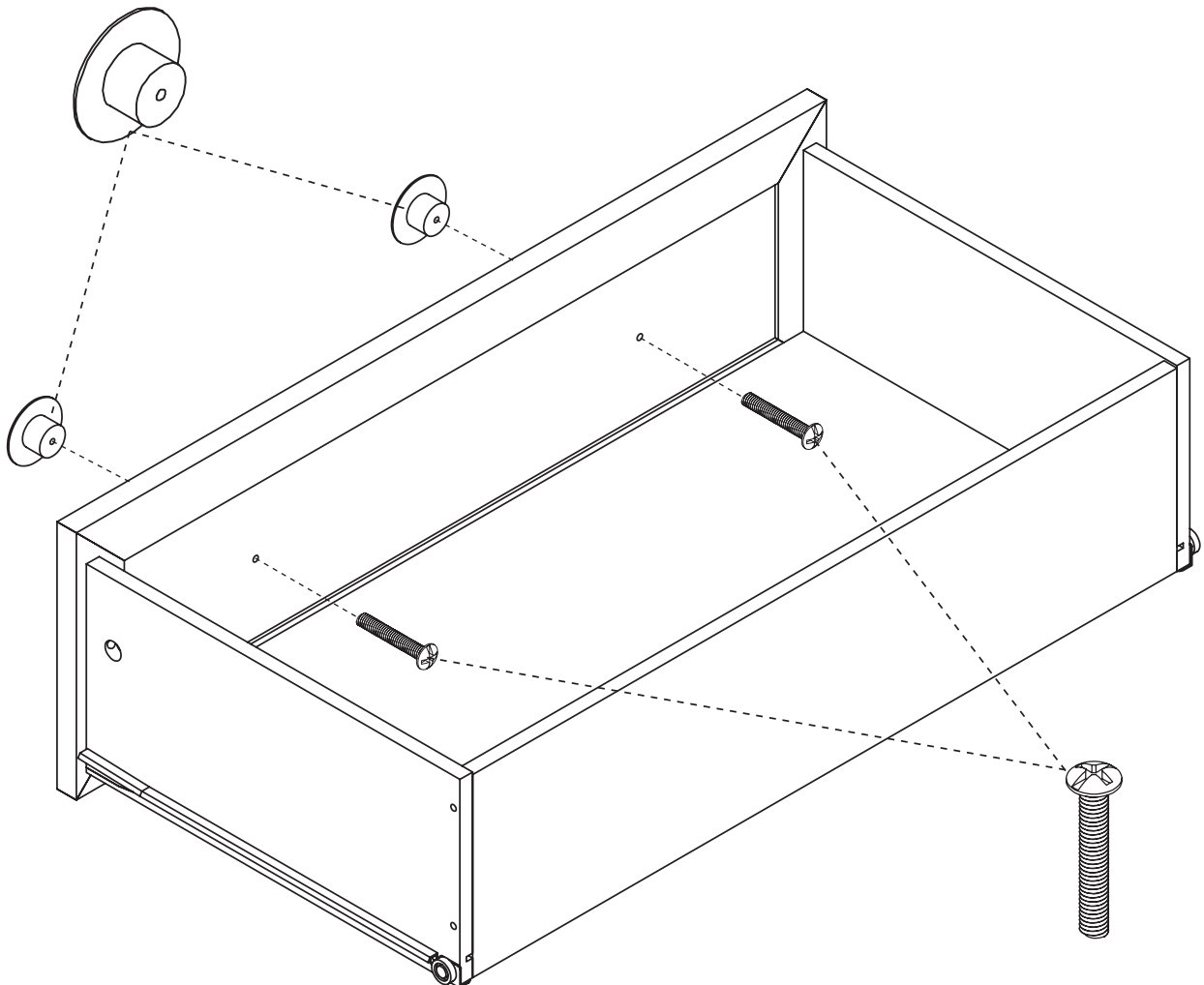

* raw edges are shaded

Step 16

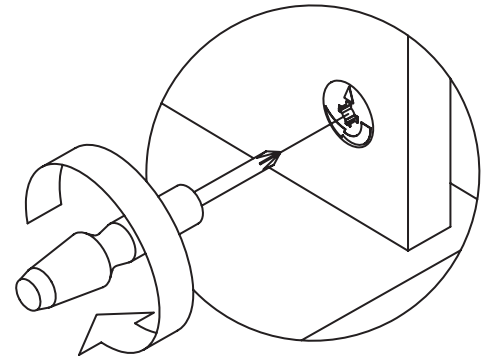
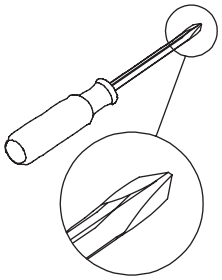

Before start, cover the work floor with any cloth or carton box paper to prevent scratch on board panel edges
 Attach top molding to left side panel.
 Must continue to hold left side panel.

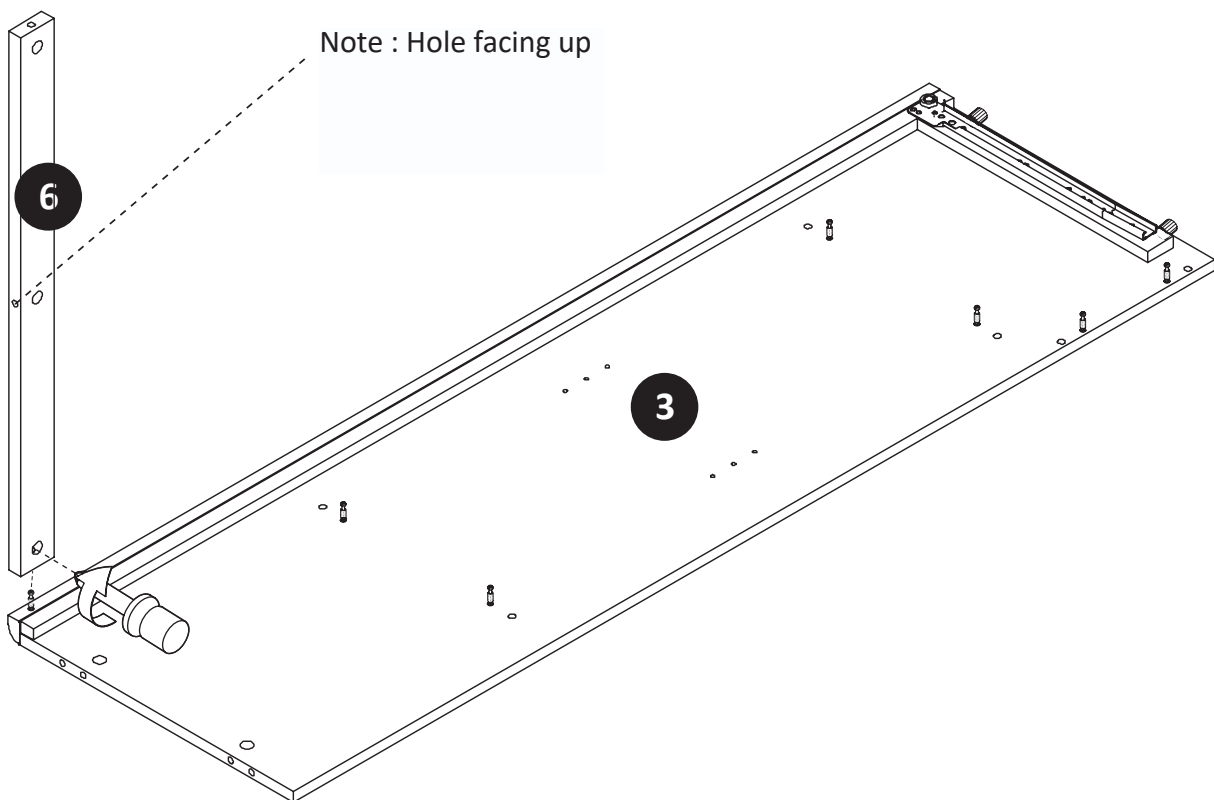

* raw edges are shaded

Step 17

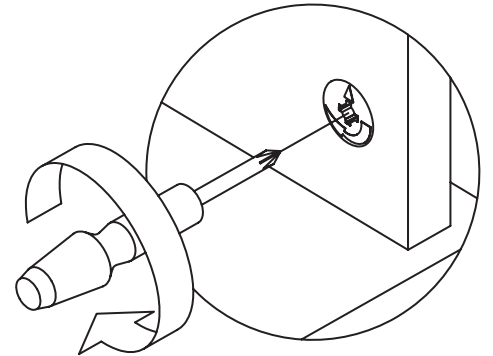
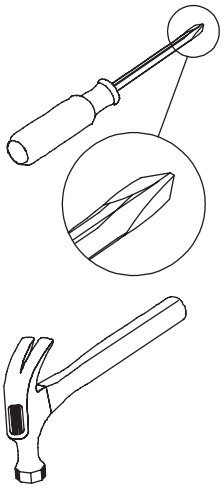

Attach the lower shelf

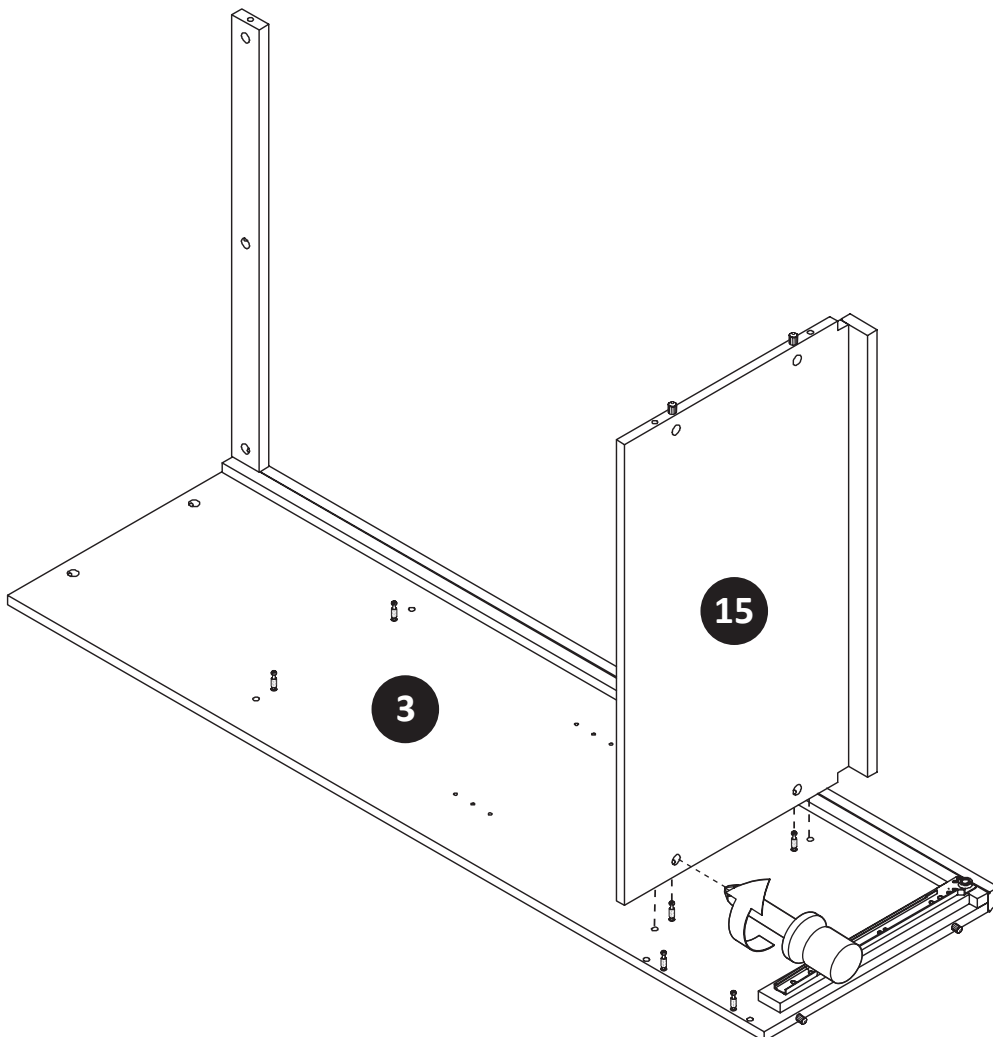

* raw edges are shaded

Step 18

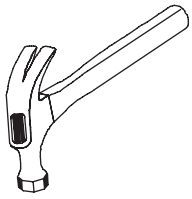

Attach the upper shelf

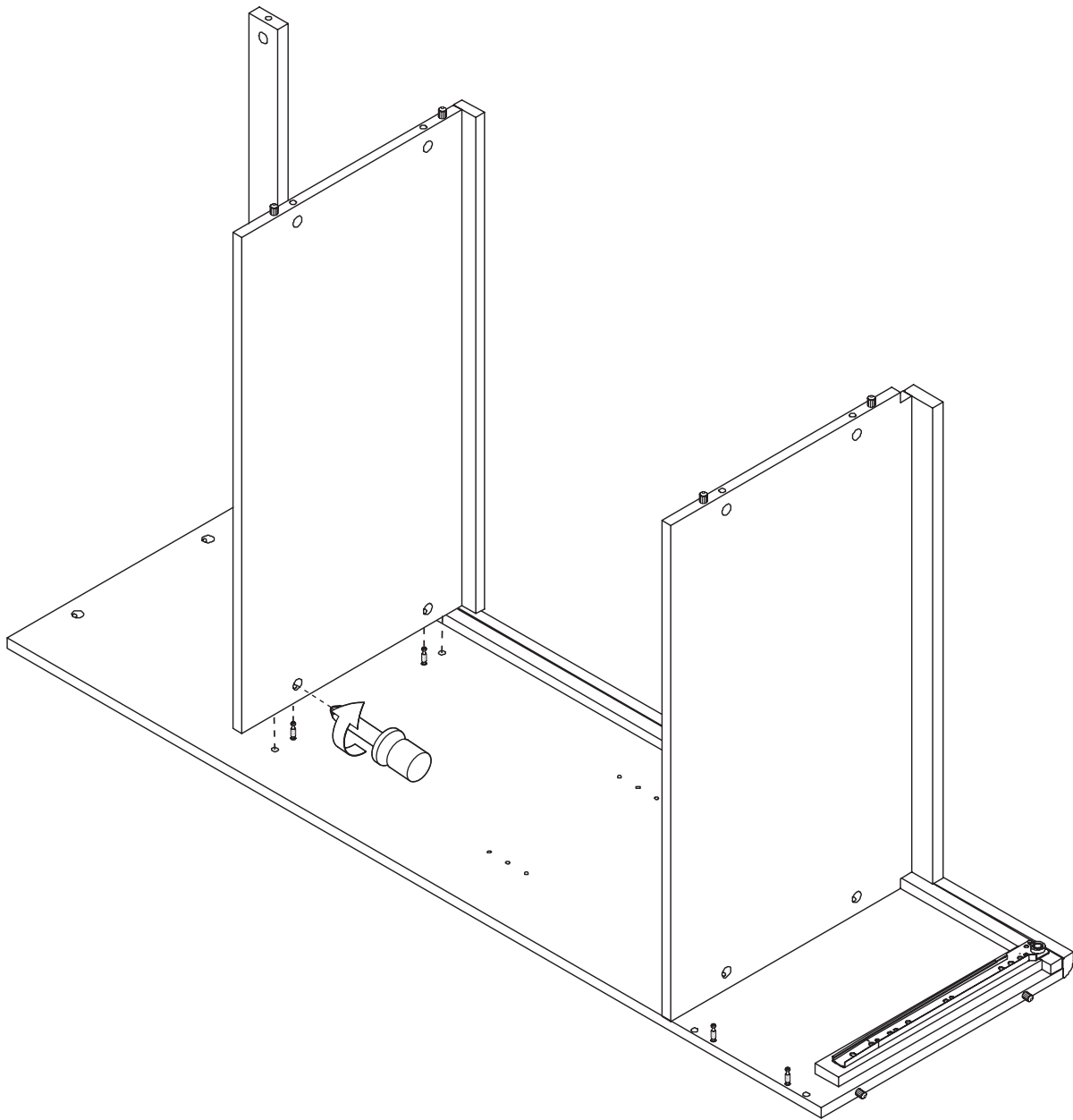
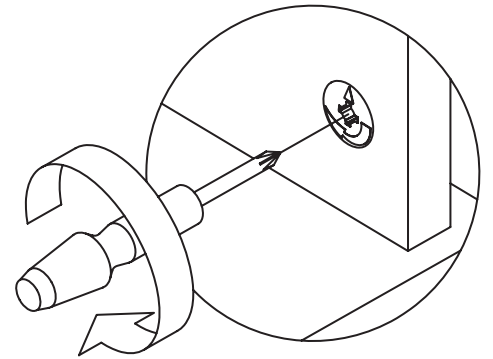

* raw edges are shaded

Step 19

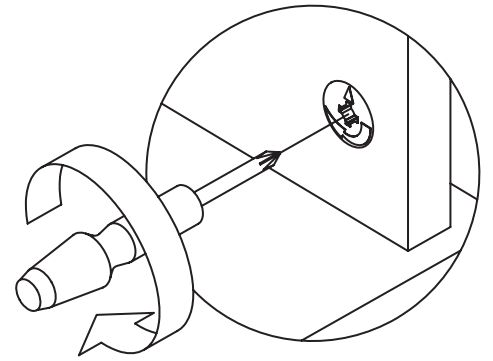
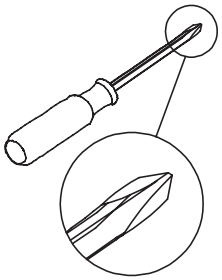

Attach the lower back panel.
Must continue to hold the lower back panel.

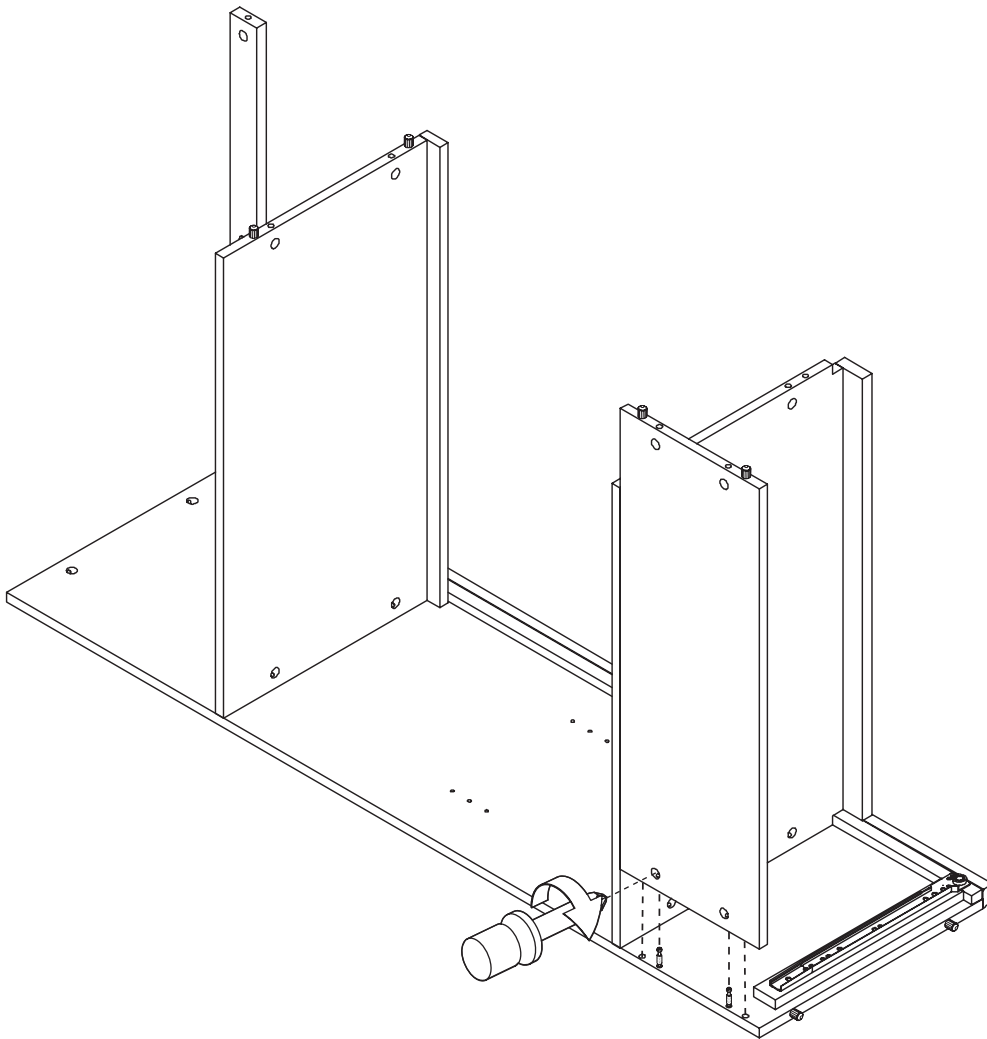

* raw edges are shaded

Step 20

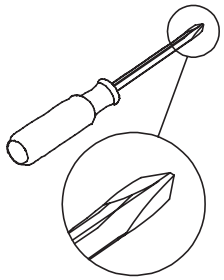

While holding the lower back panel, attach right side panel and align the connection carefully.

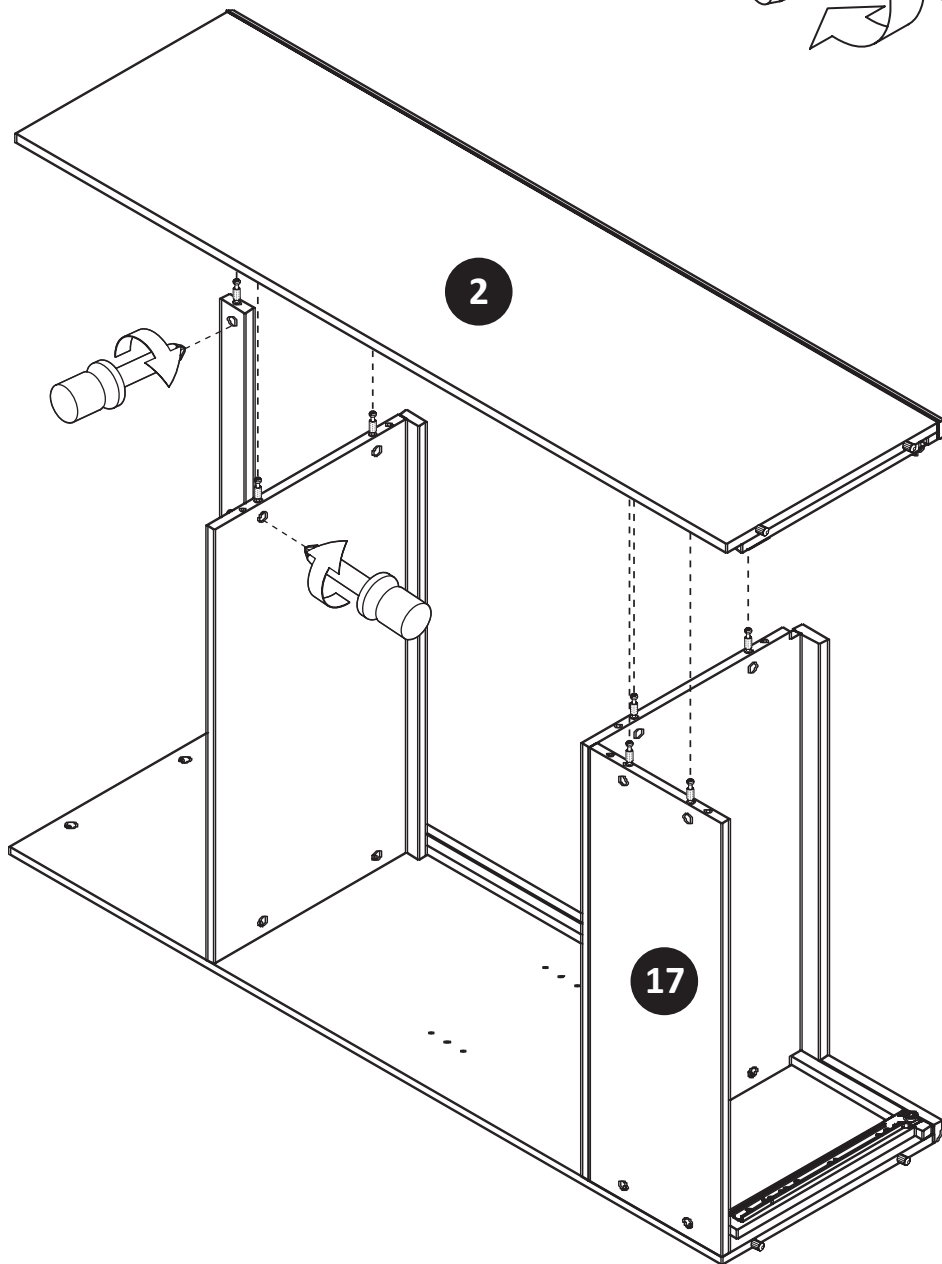
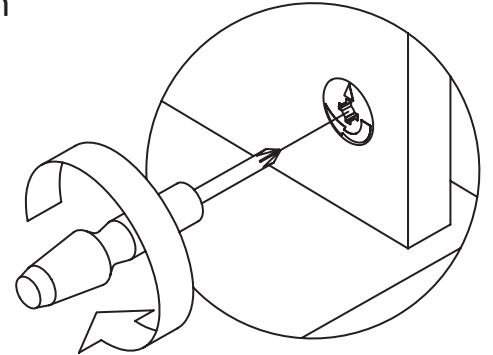

* raw edges are shaded

Step 21

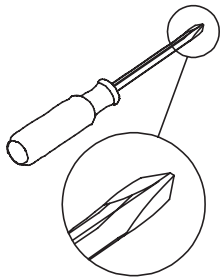

Attach the top panel carefully, do not make a harsh movements.

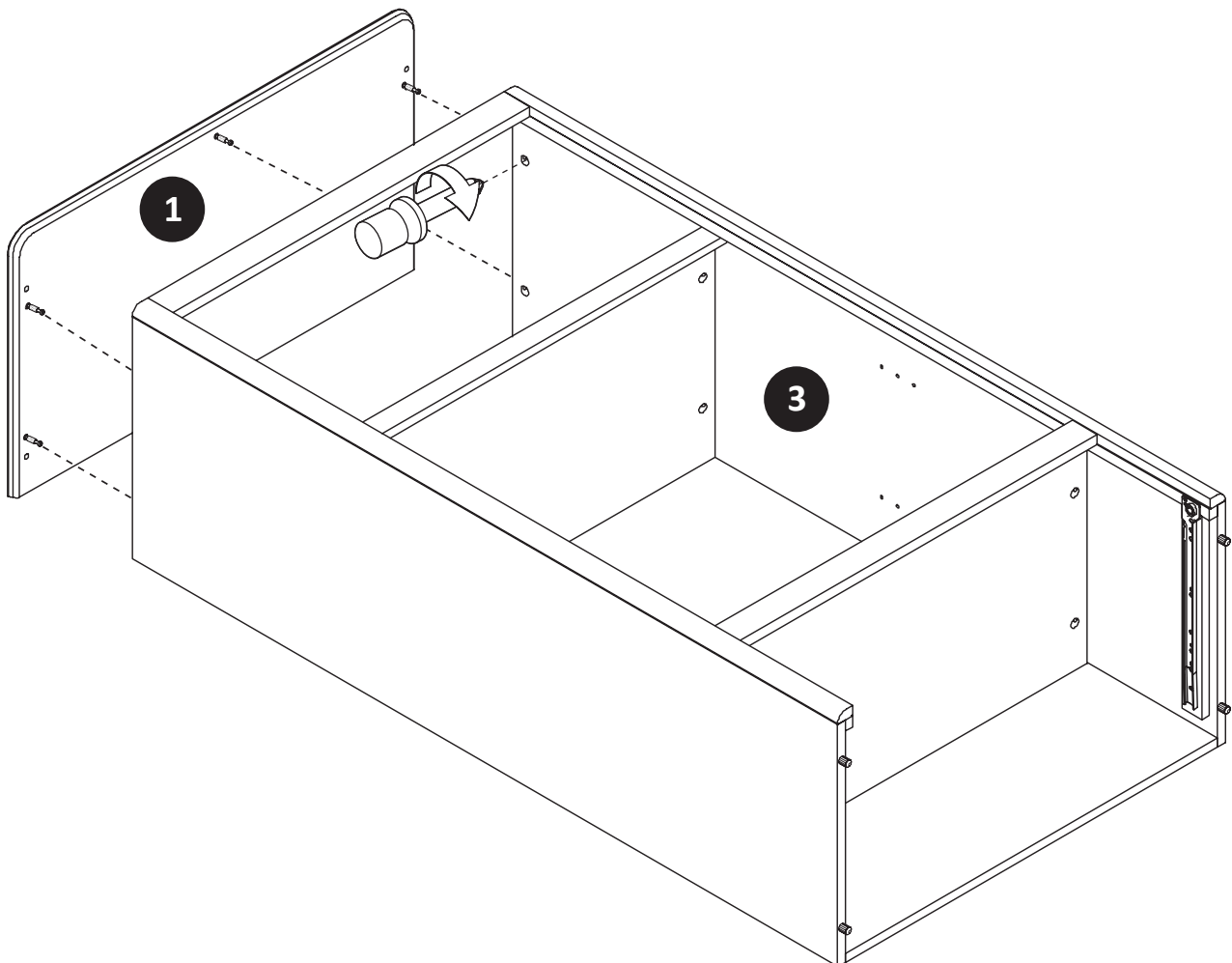
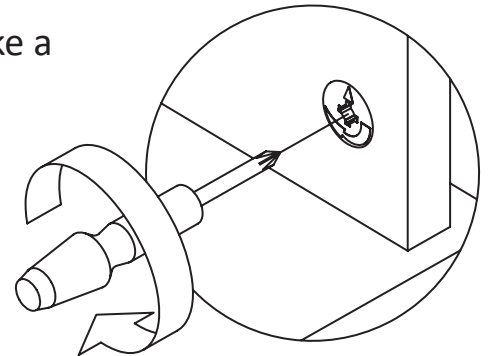

* raw edges are shaded

Step 22

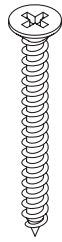
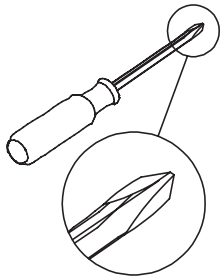

x6
TUD0009

Attach the bottom panel carefully, do not make a harsh movements.

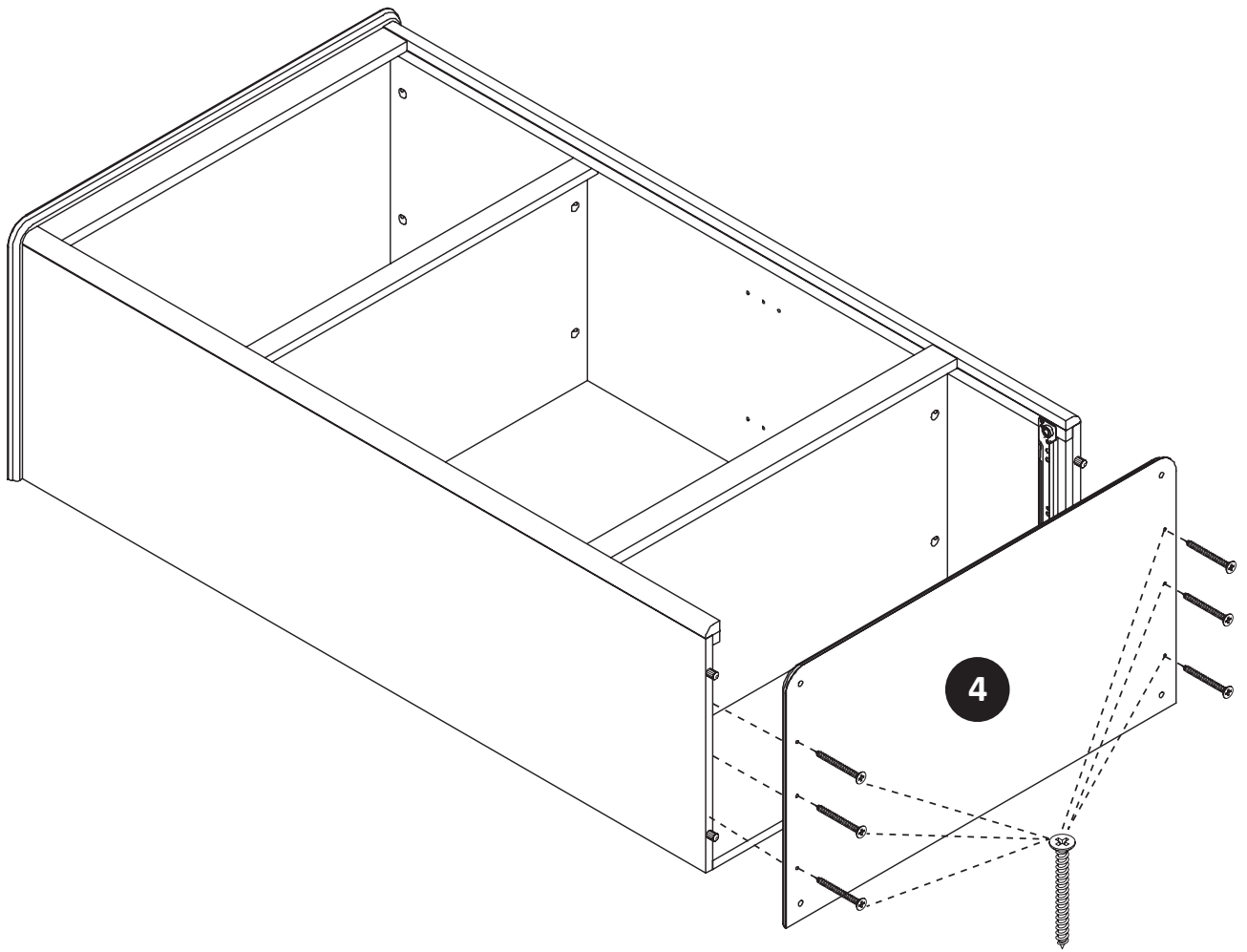

* raw edges are shaded

Step 23

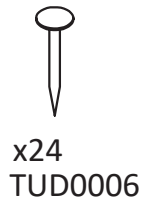
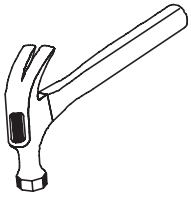

Carefully turn the unit over onto its front as shown.
Assure that the unit is square.
Distance from corner to corner must be equal as shown.

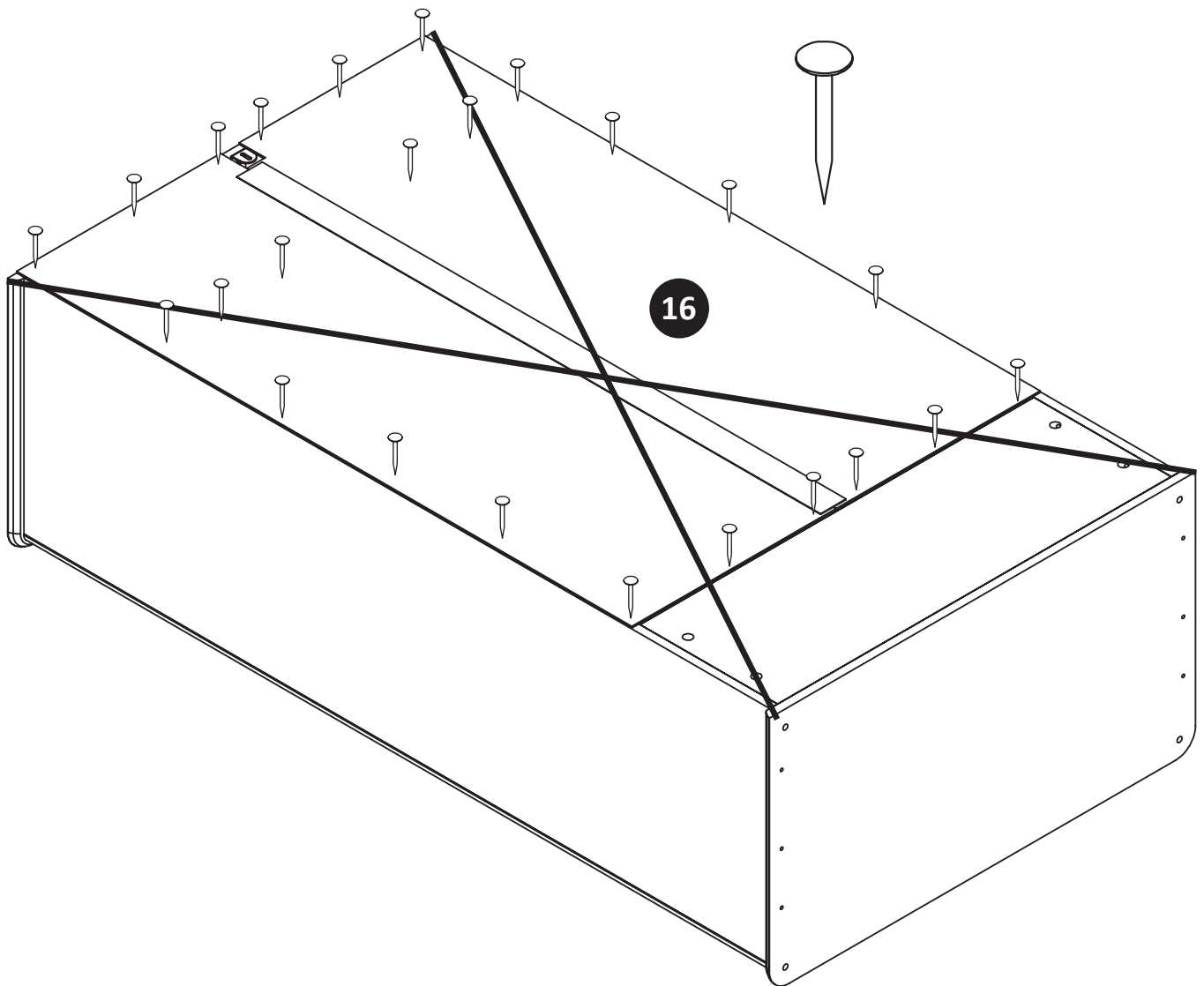

IMPORTANT! THE BACK PANEL IS A STRUCTURAL PART OF THIS UNIT AND MUST BE INSTALLED PROPERLY.

* raw edges are shaded

Step 24

Attach the legs to the bottom panel. twist clockwise until fully tighten.

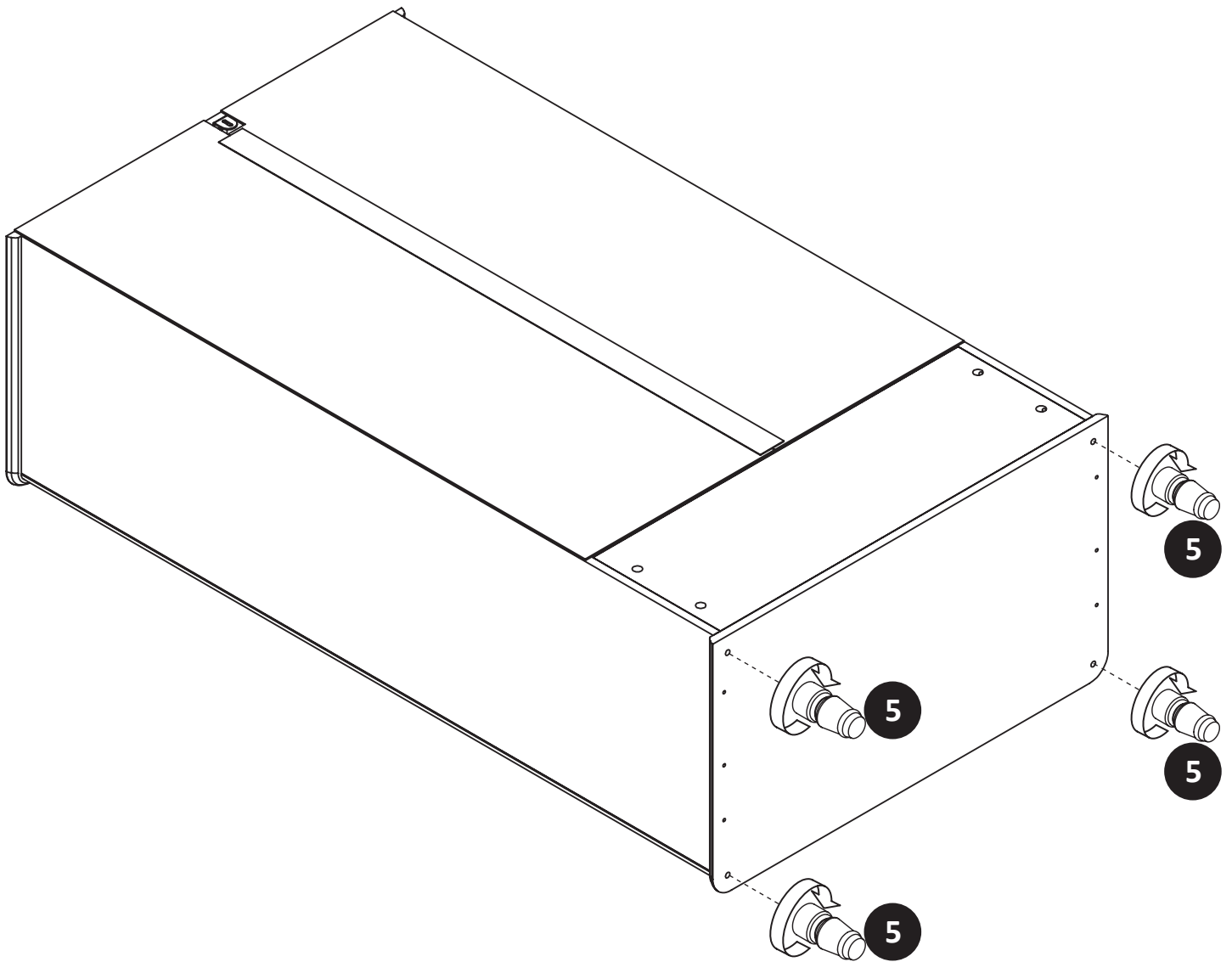

* raw edges are shaded

Step 25



x4
TUD0028

Insert shelf holder into desire height setting as shown.

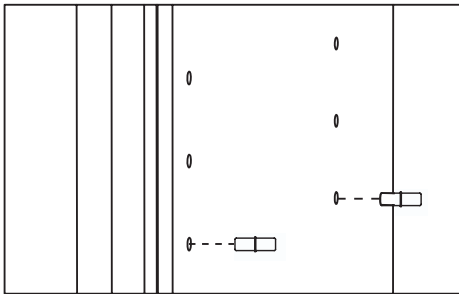

OR

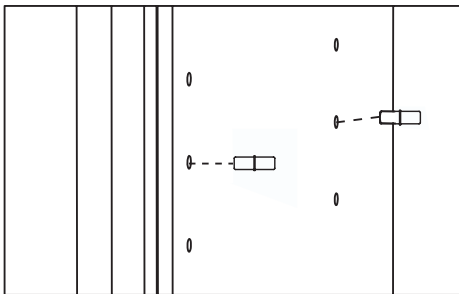

OR

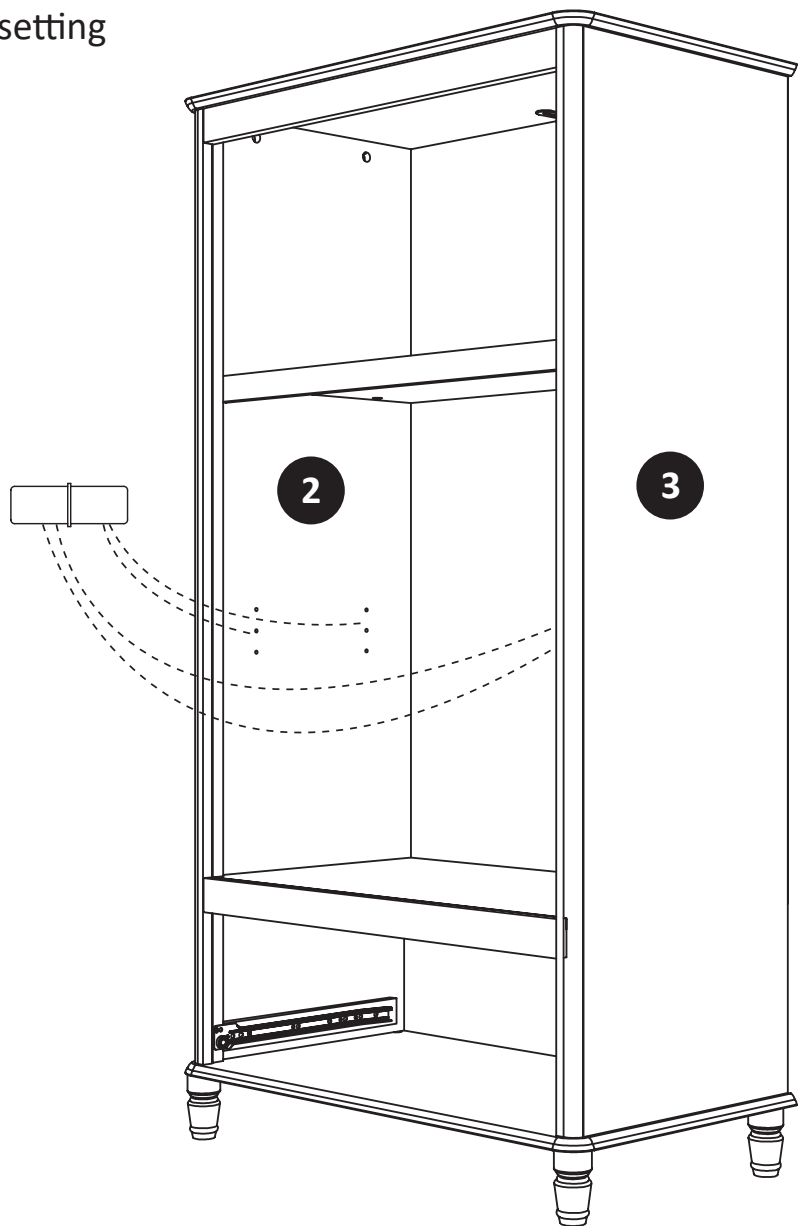
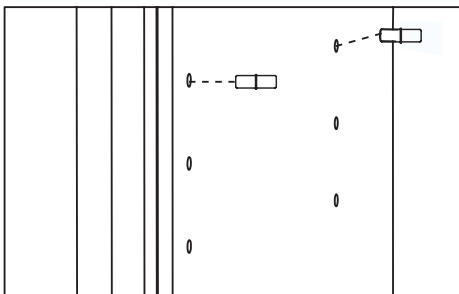

* raw edges are shaded

Step 26

Insert middle shelf all the way to the back by lower down 1 side

Adjust to normal plane and ensure sit nicely on the holders.

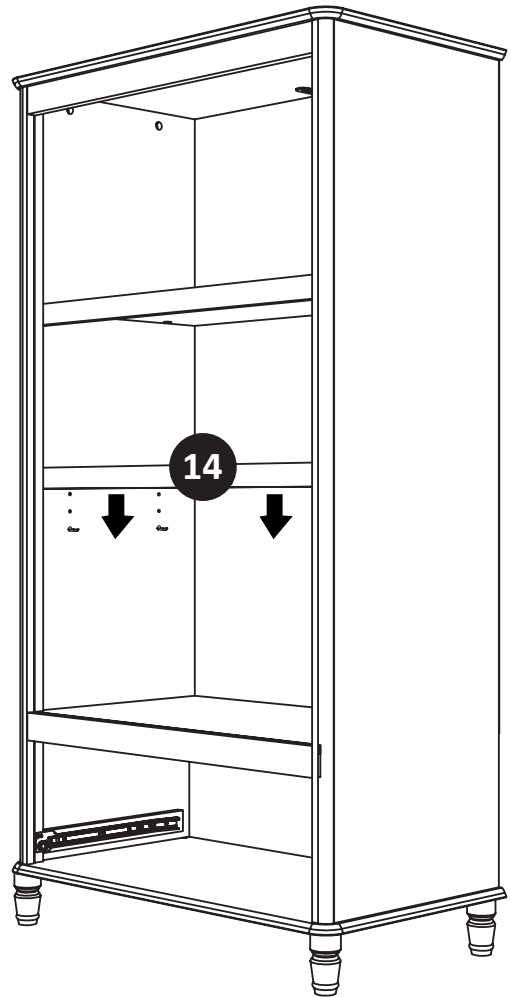
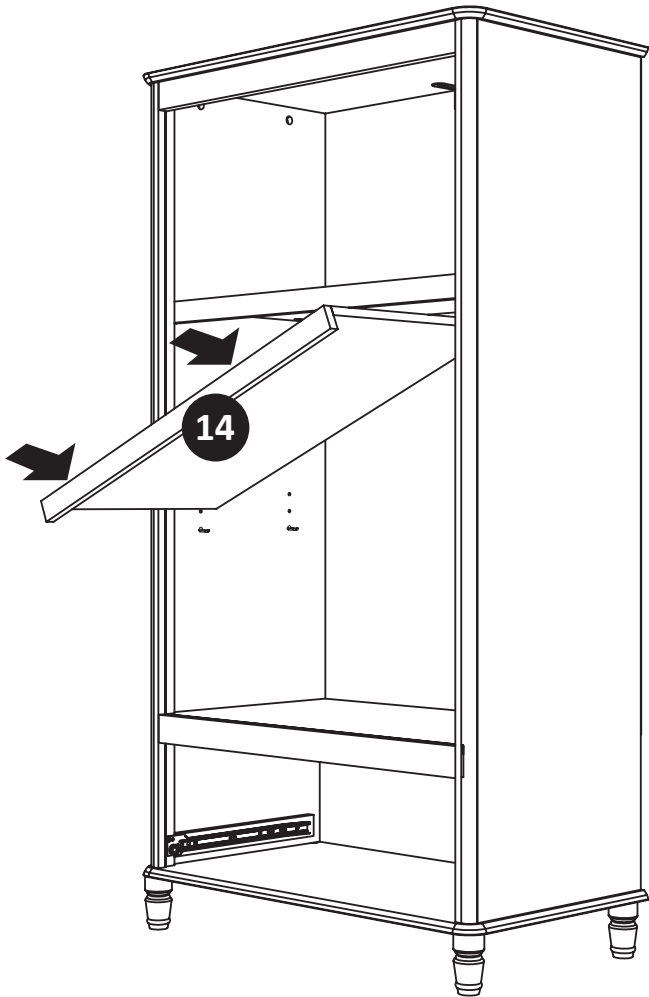

* raw edges are shaded

Step 27

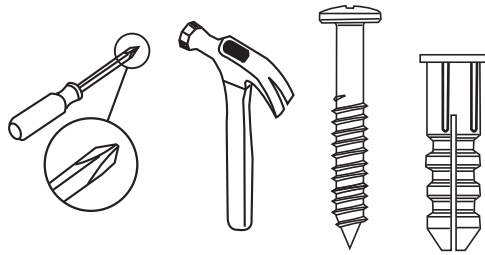

For Masonry, Concrete, or other wall materials:

Consult your local hardware store for appropriate anchors to securely attach the safety bracket.

IMPORTANT: THIS UNIT MUST BE SECURE TO THE WALL TO HELP PREVENT TIPOVER. FOLLOW THESE INSTRUCTIONS TO INSTALL THE ANTI-TIPPING SAFETY BRACKET PROVIDED WITH THIS PRODUCT.

WARNING

Serious or fatal crushing injuries can occur from furniture tipover.

To prevent tipover:

- * Install tipover restraint provided
- * place heaviest items in the lowest drawers
- * Unless specifically designed to accommodate, do not set TVs or other heavy objects on the top of this product
- * Never allow children to climb or hang on drawers, door, or shelves
- * Never open more than one drawer at a time

Use of tipover restraints may only reduce, but not eliminate the risk of tipover

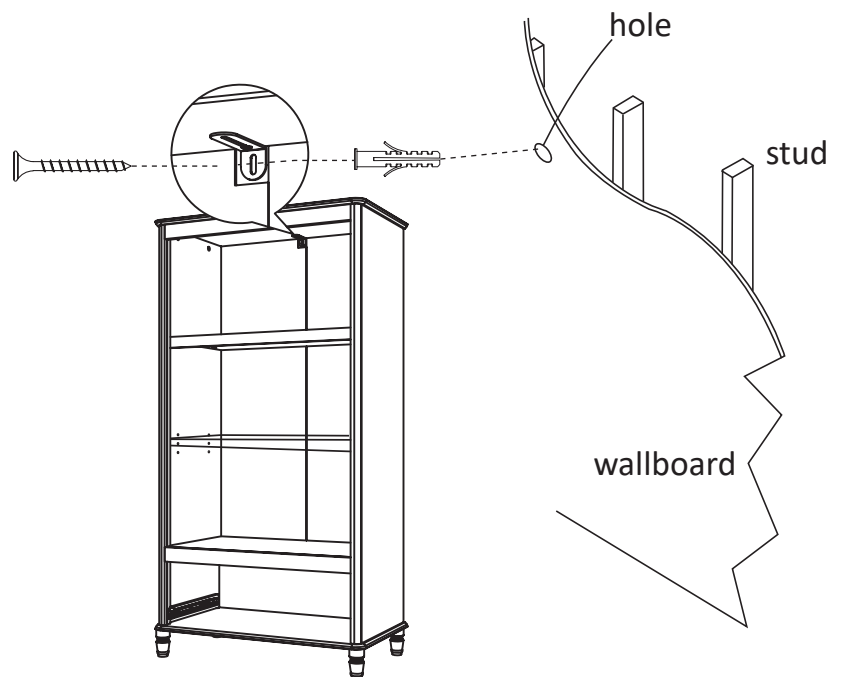

OPTION 1: Attachment into a wall stud (preferred method)

Using a stud finder, locate a stud in the wall. Place your unit against the wall, with the safety bracket aligned in this location.

To make driving the screw easier, you can drill a 1/8" diameter pilot hole (3mm) through the safety bracket into the stud.

Drive the screw through the safety bracket into the wall stud. Tighten the screw that was not fully tightened in step 1.

OPTION 2: Attachment into drywall

Locate your unit where desired against a wall and mark the wall through the safety bracket, then move your unit aside.

Drill a 3/16" diameter hole (5mm) into the wallboard. Tap the wall anchor into the hole until it is flush. Move your unit into location and fasten the wall bracket to the wall anchor with the screw.

Tighten the screw that was not fully tightened in step 1.

Step 28

Insert the drawer, carefully align the roller

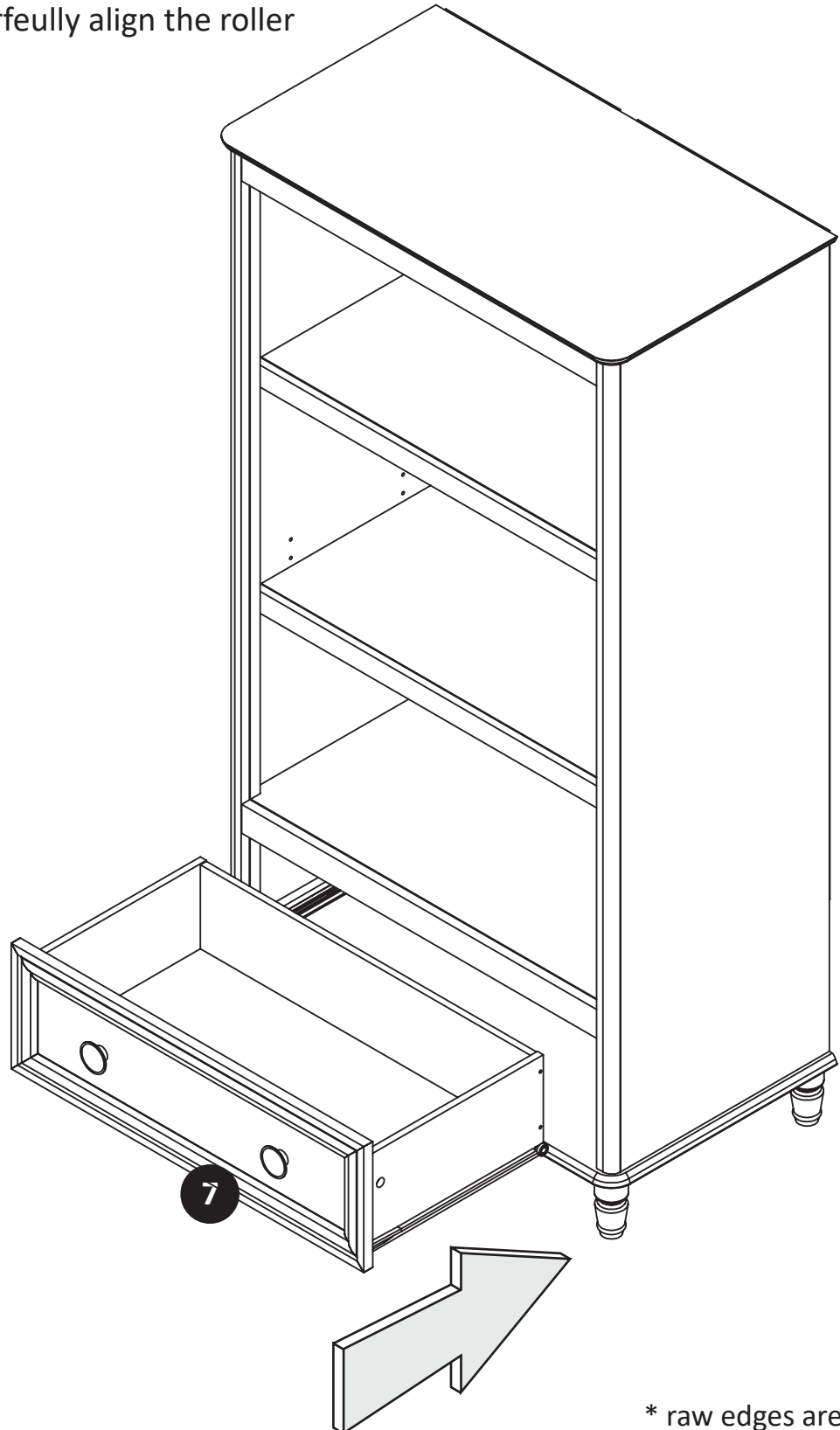

* raw edges are shaded

Maximum Loads

This unit has been designed to support the maximum loads shown. Exceeding these load limits could cause sagging, instability, product collapse, and/or serious injury.

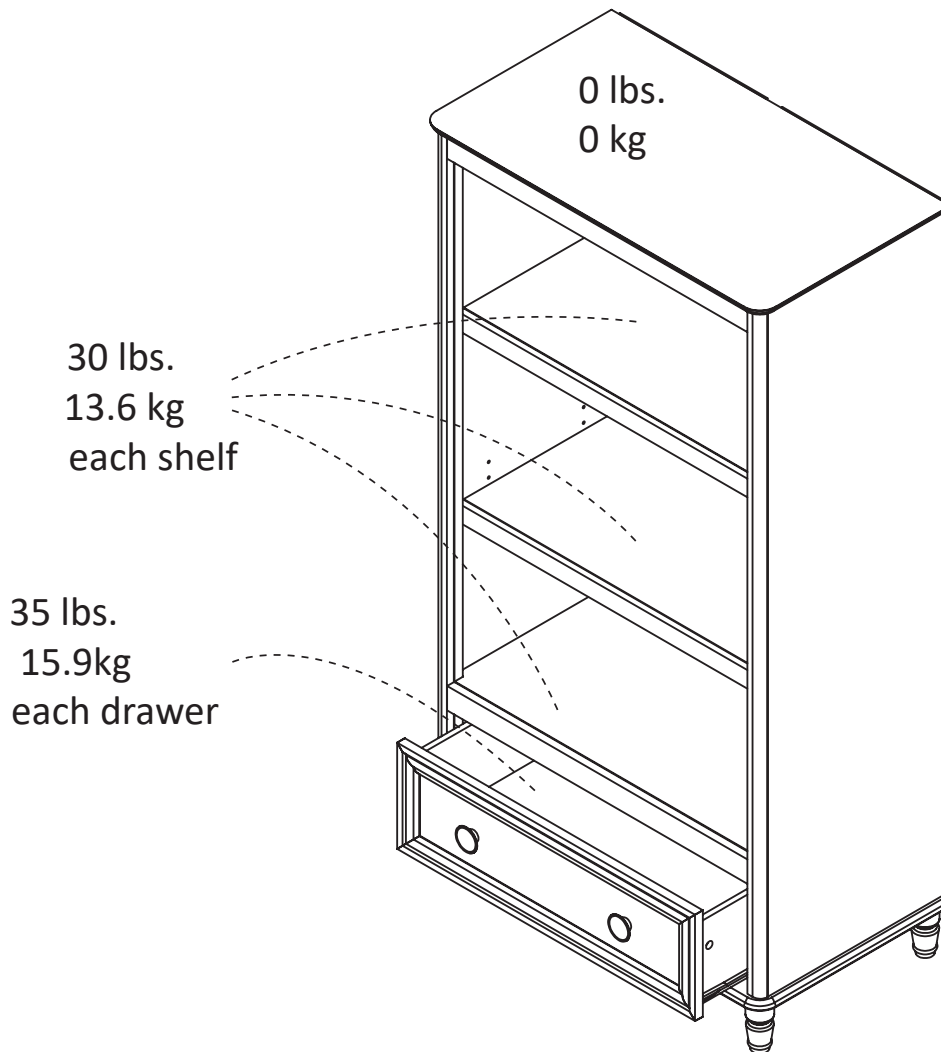

Warning: Risk of serious injury to person - do not place a television on this furniture. This furniture is not approved for use with a television.

Certificate of Conformity

1. This certificate applies to Dorel Home Furnishings, Inc. product identified by this instruction manual.
2. This certificate applies to compliance of this product with the CPSC Ban on Lead-Containing Paint (16 CFR 1303).
Dorel Home Furnishings, Inc.
3. This product is distributed by: 410 East First Street South,
Wright City, MO 63390
636-745-3351
4. Site of Manufacturer: Muar, Malaysia.
5. See front page of instruction manual for date of manufacturer.



Register your product to receive the following:



- * New trend details -sneak peek on what's new
- * Surveys -have a voice within our community
- * Exclusive deals and discount codes
- * Quick and easy replacement part service

To register your product, visit littleseedskids.com

5 Star Rating



Visit your local retailer's website, rate your purchased product and leave us some feedback!

We would like to extend a big "Thank You" to all of our customers for taking the time to assemble this Little Seeds product, and to give us your valuable feedback.

*Thank
You!*



Español

Cubierta Delantera

Busque en el interior del manual de montaje

Búsquenos!

página 2

Conserve este manual de montaje para futuras consultas.

Se recomienda dos adultos para el montaje.

Este producto no es para uso comercial.

No Regrese este producto! Para piezas perdidas o rotas.

Visitar: littleseedskids.com

Llámenos al: 1-800-489-3351 (Gratis) Lunes - Viernes 9am - 5pm CST

Seguir little seeds en

Consejos Útiles (página 3)

- Abra su artículo en el área donde usted planea utilizarlo para evitar levantar y moverlo menos
- Identificar, ordenar y contar las piezas antes de intentar ensamblar
- Las clavijas de compresión se golpean con un martillo
- Las diapositivas están marcadas con una R (derecha) y L (izquierda) para la colocación correcta
- Asegúrese de que siempre este el punto localizado en la parte superior de bloqueador de leva este volteado hacia borde exterior
- Utilizar todos los clavos para el panel de atrás y distribuirlos por igual
- El panel de atrás debe utilizarse para asegurarse de que la unidad quede fija y firme
- No use químicos fuertes ni limpiadores abrasivos en este artículo
- Nunca empuje, tire ni arrastre los muebles

Página 4

antes de que empieces

Lea cuidadosamente cada paso y siga el orden apropiado

Separar y contar todas las piezas y el hardware

Darse suficiente espacio para el proceso de montaje

Tienen las siguientes herramientas: destornillador de cabeza plana, # 2 destornillador philips cabeza y martillo

Precaución: si utiliza un taladro eléctrico o un destornillador eléctrico para atornillar, tenga cuidado de frenar y parar cuando el tornillo esté apretado. Si no lo hace, se puede quitar el tornillo

Sistema de sujeción de cerradura de leva

Este sistema de fijación de la leva se utilizará durante todo el proceso de montaje

Identificación de la Junta (página 5 y 6)

No el tamaño real

Lista de (página 7)

Tamaño real

Lista de (página 8)

No el tamaño real

Español

Paso 1 (página 9)

Conecte el bloqueo de leva. Para el soporte anti inclinación, no apriete completamente en este paso.

Paso 2 (página 10)

Preparación del panel lateral izquierdo
Orientación adecuada de CAM LOCK
Posición del tornillo

Paso 3 (página 11)

Preparación del panel lateral derecho
Orientación adecuada de CAM LOCK
Posición del tornillo

Paso 4 (página 12)

Preparación del panel posterior inferior y moldeo superior
Orientación adecuada de CAM LOCK

Paso 5 (página 13)

Preparación de estantes superiores e inferiores

Paso 6 (página 14)

Preparación del cajón frontal

Paso 7 (página 15)

Preparación del cajón izquierdo y derecho

Paso 8 (página 16)

Preparación del soporte del cajón

Paso 9 (página 17)

Coloque el cajón izquierdo en el cajón delantero.

Paso 10 (página 18)

Coloque el cajón derecho en el cajón delantero

Paso 11 (página 19)

Coloque el soporte del cajón en el cajón delantero

Paso 12 (página 20)

Ranura en el cajón inferior

Paso 13 (página 21)

Fije el cajón trasero con el tornillo

Español

Paso 14 (página 22)

Coloque la corredera del cajón para la caja del cajón

Paso 15 (página 23)

Instalación de la perilla

Paso 16 (página 24)

Antes de comenzar, cubra el piso de trabajo con cualquier paño o papel de caja de cartón para evitar rasguños en los bordes del panel

Conecte el moldeo superior al panel lateral izquierdo.

Debe continuar sosteniendo el panel lateral izquierdo.

Paso 17 (página 25)

Sujete el estante inferior

Paso 18 (página 26)

Fije el estante superior

Paso 19 (página 27)

Coloque el panel posterior inferior.

Debe continuar sosteniendo el panel posterior inferior.

Paso 20 (página 28)

Mientras sostiene el panel posterior inferior, coloque el panel lateral derecho y alinee la conexión con cuidado.

Paso 21 (página 29)

Sujete el panel superior cuidadosamente, no haga movimientos bruscos.

Paso 22 (página 30)

Sujete el panel inferior cuidadosamente, no haga movimientos bruscos.

Paso 23 (página 31)

Con cuidado, gire la unidad sobre su parte frontal como se muestra.

Asegúrese de que la unidad es cuadrada.

La distancia de la esquina a la esquina debe ser igual a como se muestra.

¡IMPORTANTE! EL PANEL TRASERO ES UNA PARTE ESTRUCTURAL DE ESTA UNIDAD Y DEBE INSTALADO CORRECTAMENTE.

Español

Paso 24 (página 32)

Sujete las patas al panel inferior. Gire hacia la derecha hasta apretar completamente.

Paso 25 (página 33)

Inserte el soporte de la repisa en el ajuste de la altura del deseo como se muestra.

Cara Plana,
Hacia arriba

Paso 26 (página 34)

Inserte el estante del medio todo el camino hasta la parte posterior por abajo hacia abajo 1 lado
Ajuste a plano normal y asegúrese de sentarse bien en los titulares.

Paso 27 (página 35)

Para los materiales de la mansión, hormigón u otra pared:

Consulte su local de hardwarestore para anclajes adecuados para fijar firmemente el soporte de seguridad.

Advertencia

Las lesiones de aplastamiento severas o mortales pueden ocurrir de los muebles verdes.

Para evitar golpes:

* Instale la restricción de tipo

Coloque los artículos más pesados en los cajones inferiores

* A menos que esté diseñado específicamente para acomodar, no coloque televisores u otros objetos pesados encima de este producto

* Nunca es posible que los niños se sienten y cuelguen en cajones, puertas o estantes

Nunca abra a un cajon a la vez

El uso de restricciones de tipo sólo puede reducir, pero no eliminar el tipo de riesgo

Opción 1: fijación a un perno de pared (método preferido)

Usando un buscador de haz, ubique un espárrago en la pared. Coloque su unidad contra la pared, con el brazo de seguridad alineado en este lugar

Para facilitar el accionamiento del tornillo, puede perforar un orificio guía de 1/8 "de diámetro (3 mm) a través del soporte de seguridad del perno

Atornille el tornillo a través del soporte de seguridad en el perno de pared. Apriete el tornillo que no fue completamente tocado en el paso 1

Opción 2: fijación a la pared de yeso

Localice la unidad donde desee en una pared y marque la pared a través del soporte de seguridad, después mueva la unidad a un lado.

Taladre un orificio de 3/16 "de diámetro (5 mm) en la placa de pared, rebote el anclaje de pared en el orificio hasta que quede al ras.

Mueva la unidad a la ubicación y fije el soporte de pared al ancla de pared con el tornillo.

Apriete el tornillo que no está totalmente apretado en el paso 1.

Paso 28 (página 36)

Insertar el cajón, alinear el rodillo

Página 37

La unidad máxima ha sido diseñada para soportar las cargas máximas mostradas. Exceder estos límites de carga podría causar flacidez, inestabilidad, colapso del producto y / o lesiones graves. Advertencia: riesgo de lesiones graves a la persona - no coloque un televisor en este mueble. Este mobiliario no está aprobado para su uso con un televisor.

Certificado de confirmación

1. este certificado se aplica al producto Dorel Home Furnishings, Inc. identificado por este manual de instrucciones.
2. este certificado se aplica al cumplimiento de este producto con la prohibición de la CPSC sobre pintura que contenga plomo (16 CFR 1303)
3. Este producto se distribuye por: 410 East primera calle sur, ciudad de wright, MO 63390 636-745-3351
4. sitio del fabricante: Muar, Malasia
5. ver la página frnt del manual de instrucciones para la fecha del fabricante.

Página 38

Registre su producto para recibir lo siguiente:

- * Nuevos detalles sobre las tendencias - Sneek echa un vistazo a lo nuevo
- * Encuestas - tener una voz dentro de nuestra comunidad
- * Ofertas exclusivas y códigos de descuento

Servicio de piezas de repuesto rápido y fácil

Para registrar su producto, visite littleseedskids.com

5 estrellas

Visite el sitio web de su distribuidor local, califique su producto comprado y déjenos algunos comentarios!

Nos gustaría extender un gran "Gracias" a todos nuestros clientes por tomarse el tiempo para montar este producto littleseedskids, y para darnos sus valiosos comentarios

Gracias!

Français

Capot Avant
Regardez à l'intérieur du manuel d'assemblage
Búsquenos!

page 2

Conservez ce manuel d'installation pour référence ultérieure.
deux adultes pour l'installation est recommandée.
Ce produit n'est pas pour un usage commercial.

Ne pas retourner ce produit! Pour les pièces perdues ou cassées.
Visite: littleseedskids.com
Appel: 1-800-489-3351 (gratuit) Lundi - Vendredi 9am - 5pm CST

Suivez les petites graines dans

Conseil (page 3)

- Ouvrez votre article dans la zone où vous prévoyez de l'utiliser pour éviter de soulever et déplacer moins
- Identifier, trier et compter les pièces avant de monter
- bouchons de compression sont frappés avec un marteau
- Les lames sont marqués par un R (droite) et L (à gauche) pour le positionnement correct
- Assurez-vous toujours ce point, je Aviana sur le dessus de la came de blocage ce bord extérieur volteado hacia
- Utilisez tous les clous du panneau arrière et les distribuer également
- Le panneau arrière doit être utilisé pour faire en sorte que l'unité est fixe et ferme
- Ne pas utiliser de produits chimiques ou de produits abrasifs sur cet article
- Ne jamais pousser, tirer ou meubles de glisser

page 4

avant de commencer

Lisez chaque étape attentivement et suivre le bon ordre

Séparée et comptez toutes les pièces et matériel

Soyez assez d'espace pour le processus d'assemblage

Ils ont les outils suivants: tournevis, # 2 tournevis Phillips et tête de marteau

Attention: Si vous utilisez une perceuse électrique ou un tournevis électrique à vis, faites attention à freiner et arrêter lorsque la vis est serrée. Si vous ne le faites pas, vous pouvez retirer la vis

Fixation de verrouillage de came Système

Ce système de fixation cam être utilisé tout au long du processus d'assemblage

Identification du Conseil (page 5 et 6)

Pas taille réelle

Liste (page 7)

taille réelle

Liste (page 8)

Pas taille réelle

Français

Paso 1 (page 9)

Conecte el bloqueo de leva. Para el soporte anti inclinación, no apriete completamente en este paso.

Paso 2 (page 10)

Préparation du panneau latéral gauche
Orientación adecuada de CAM LOCK
Posición del tornillo

Paso 3 (page 11)

Préparation du panneau latéral derecho
Orientación adecuada de CAM LOCK
Posición del tornillo

Paso 4 (page 12)

Préparation du panneau postérieur inférieur et moulé supérieur
Orientación adecuada de CAM LOCK

Paso 5 (page 13)

Préparation des étages supérieurs et inférieures

Paso 6 (page 14)

Preparación del cajón frontal

Paso 7 (page 15)

Préparation du cajón gauche et droit

Paso 8 (page 16)

Préparation du support de cajón

Paso 9 (page 17)

Coloque el cajón izquierdo en el cajón delantero.

Paso 10 (page 18)

Coloque el cajón derecho en el cajón delantero

Paso 11 (page 19)

Coloque le support du cajon en el cajón delantero

Etape 12 (page 20)

Fente dans le tiroir du bas

Français

Étape 13 (page 21)

tiroir arrière sécurisé avec vis

Étape 14 (page 22)

Placez le tiroir à boîte de tiroir

Étape 15 (page 23)

Installation du bouton

Étape 16 (page 24)

Avant de commencer, couvrir le plancher de travail avec un carton de tissu ou du papier pour éviter les rayures sur les bords du panneau

Pour connecter le moulage par panneau latéral supérieur gauche.

Vous devez continuer à tenir le panneau latéral gauche.

Étape 17 (page 25)

Tenez la tablette inférieure

Étape 18 (page 26)

Fixer l'étagère supérieure

Étape 19 (page 27)

Placez le panneau arrière inférieur.

Vous devez continuer à soutenir le panneau arrière inférieur.

Étape 20 (page 28)

Tout en maintenant le panneau arrière inférieur, placez le panneau latéral droit et aligner soigneusement la connexion.

Étape 21 (page 29)

Tenez le panneau supérieur et de ne pas faire de mouvements brusques.

Étape 22 (page 30)

Tenez le panneau inférieur et de ne pas faire de mouvements brusques.

Étape 23 (page 31)

Tourner avec précaution l'appareil sur son front comme indiqué.

Assurez-vous que l'unité est carrée.

La distance d'un coin à doit être égal comme indiqué.

IMPORTANT! LE PANNEAU ARRIÈRE EST STRUCTURELLE PARTIE DE CETTE UNITÉ ET MUST INSTALLÉ.

Étape 24 (page 32)

Serrer les jambes au panneau inférieur. Tourner dans le sens horaire jusqu'à ce que complètement serré.

Étape 25 (page 33)

Insérez le support de plateau pour ajuster la hauteur du désir comme indiqué.

Visage plat,

En haut

Étape 26 (page 34)

Insérez l'étagère du milieu tout le chemin vers le bas vers le bas un côté

Régler au plan normal et assurez-vous de rester bien dans les gros titres.

* Les bords bruts sont grisées

Étape 27 (page 35)

Pour les matériaux de la maison, en béton ou autre mur:

Consultez votre quincaillerie locale pour une bonne chevilles pour fixer fermement le support de sécurité.

avertissement

blessures par écrasement graves ou la mort peuvent se produire des meubles verts.

Pour éviter tout choc:

* Installer la restriction de type

Placez les articles plus lourds dans les tiroirs inférieurs

* À moins que vous spécifiquement Prédiposition pour ne pas mettre les téléviseurs ou d'autres objets lourds sur ce produit

* Il est jamais possible pour asseoir les enfants et accrocher dans des tiroirs, des portes ou des étagères

Ne jamais ouvrir un tiroir à la fois

L'utilisation de ces restrictions ne peut réduire mais pas éliminer le type de risque

Option 1: fixation sur un poteau de mur (préféré)

Utilisation d'un détecteur de faisceau, localiser un goujon dans le mur. Placez votre appareil contre le mur, le bras aligné avec la sécurité à cet endroit

Pour faciliter le fonctionnement de la vis peut percer un trou pilote 1/8 « de diamètre (3 mm) à travers la broche de support de sécurité

Visser le support à travers le montant du mur de sécurité. Serrer la vis qui n'a pas été complètement touché à l'étape 1

Option 2: fixation de plaques de plâtre

Localiser l'unité lorsque cela est désiré dans une paroi de la paroi et la marque à travers le support de sécurité, puis déplacer de côté de l'appareil.

Percer un 3/16 « de diamètre (5 mm) dans la plaque de paroi, l'ancre de mur de rebondissement dans le trou jusqu'à ce qu'il soit au même niveau.

Déplacez le lecteur à l'emplacement et fixez le support mural sur la fixation murale avec vis.

Serrer la vis est serrée à fond dans l'étape 1.

Français

Étape 28 (page 36)

Insérez le tiroir, le rouleau d'alignement

Page 37

L'unité maximale est conçue pour résister aux charges maximales indiquées. Le dépassement de ces limites de charge pourrait provoquer l'affaissement, instabilité, effondrement du produit et / ou des blessures graves.

Attention: risque de blessures graves à la personne - ne pas mettre une télévision dans l'armoire. Ce mobilier est pas approuvé pour une utilisation avec un téléviseur.

certificat de confirmation

1. Ce certificat produit Dorel Mobilier de maison, Inc. identifié par ce mode d'emploi applique.
2. Ce certificat de conformité est appliqué au produit avec l'interdiction de la peinture au plomb de la CPSC (16 CFR 1303)
3. Ce produit est distribué par: 410 East First Street South, wright, MO 63390 636-745-3351
4. Site du fabricant: Muar, Malaisie
5. frnt voir le manuel d'instructions de la page pour la date du fabricant.

Page 38

Enregistrez votre produit pour recevoir les éléments suivants:

- * De nouveaux détails sur les tendances - Sneek vérifier la nouvelle
 - * Sondages - ont une voix dans notre communauté
 - * Offres exclusives et des codes de réduction
- Service de pièces de rechange rapide et facile

Pour enregistrer votre produit, visitez littleseedskids.com

5 étoiles

Visitez le site Web de votre distributeur local, classez votre produit acheté et laisser des commentaires!

Nous voudrions étendre un grand « Merci » à tous nos clients pour prendre le temps de monter ce littleseed-skids produit, et de nous faire part de vos précieux commentaires

Merci!